

■ Features

- On-chip amplification and temperature compensations
- Pre-calibration of offset voltage and span
- Dual-in-line package (DIP)

■ Applications

- Industrial instrumentation
- Pressure switch, Pneumatic device
- Medical device

■ Part number for ordering

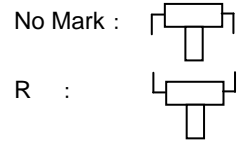
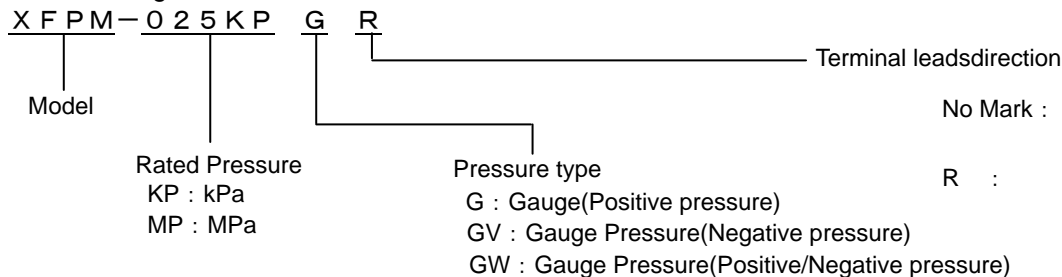

**RoHS compliance**

Measurable pressure range(kPa)	Part number for ordering	
	-100~100	XFPM-100KPGW
0~-100	XFPM-100KPGV	XFPM-100KPGVR
0~25	XFPM-025KPG	XFPM-025KPGR
0~50	XFPM-050KPG	XFPM-050KPGR
0~100	XFPM-100KPG	XFPM-100KPGR
0~200	XFPM-200KPG	XFPM-200KPGR
0~1000	XFPM-001MPG	XFPM-001MPGR

■ Specifications

Model	100KPGW	100KPGV	025KPG	050KPG	100KPG	200KPG	001MPG	Unit
<b>Recommended operating conditions</b>								
Pressure type	Gauge pressure							—
Rated pressure	±100	-100	25	50	100	200	1000	kPa
Measurable pressure range	-100~100	0~-100	0~25	0~50	0~100	0~200	0~1000	kPa
Temperature range	0~85							°C
Pressure media	Non-corrosive gases only (No liquid)							—
Supply voltage (constant)	5±0.25							VDC
<b>Absolute maximum rating</b>								
Maximum load pressure	Twice of rated pressure						1.5 times of rating pressure	—
Maximum excitation voltage	8							VDC
Operating temperature	-40~125							°C
Storage temperature	-40~125							°C
Operating humidity	30~80 (Non dew condition)							%RH
<b>Electrical characteristics (Excitation voltage Vcc=5.0V constant , ambient temperature Ta=25°C)</b>								
Power consumption	10mA max.							mA
Output impedance	10Ω max.							Ω
Source current	0.2mA max.							mA
Sink current	2mA max.							mA
Response time	2 (for the reference)							msec
Output span voltage	4.5							V
Offset voltage *1	*2	*3	0.2±0.1125 (at 0 kPa )				V	
Output voltage at full scale *1	*4	*5	4.7±0.1125 (at rated pressure)				V	
Accuracy *1	±2.5							%FS/0~85°C

\*1 Excluding input voltage error.  
 \*2 0.2±0.1125V(at -100kPa)    \*3 0.2±0.1125V(at 0kPa)  
 \*4 4.7±0.1125V(at +100kPa)    \*5 4.7±0.1125V(at -100kPa)

■ Outline dimensions ■

XFPM

unit : mm

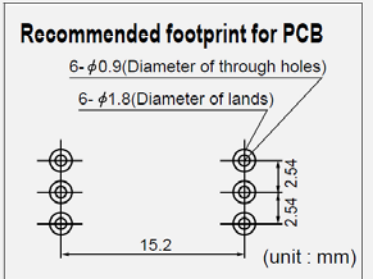
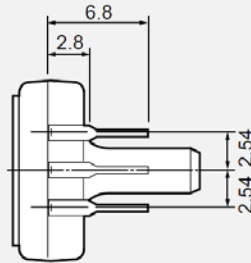
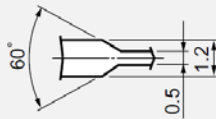
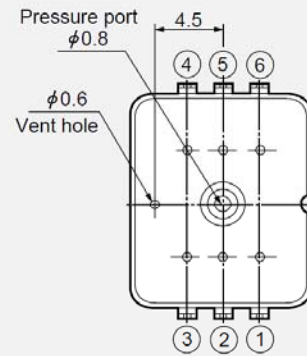
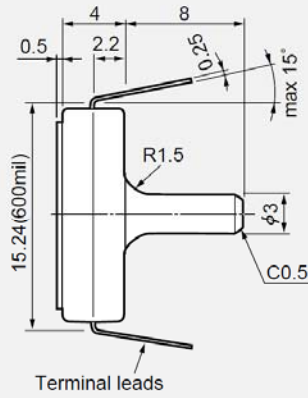
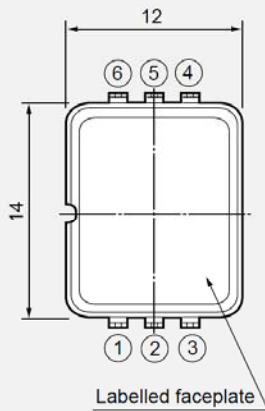

XFPM-R

unit : mm

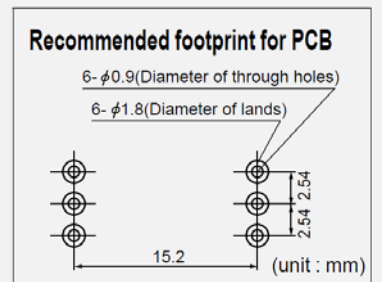
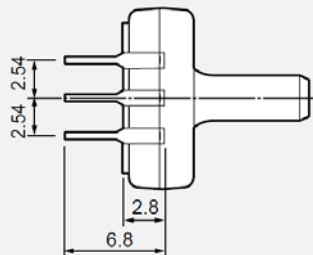
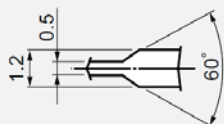
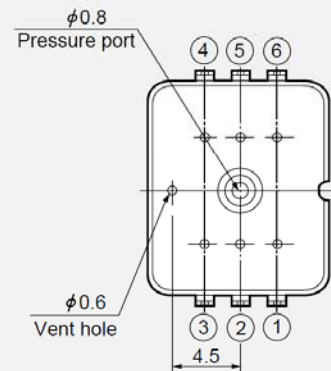
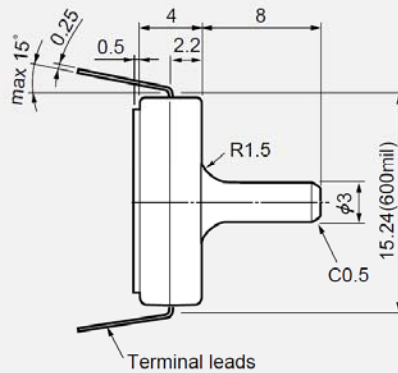
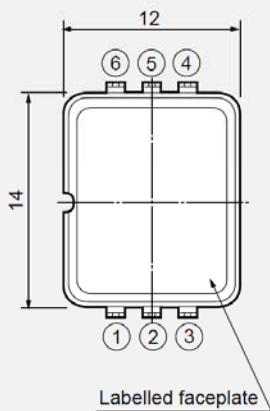

■ Connection diagram ■

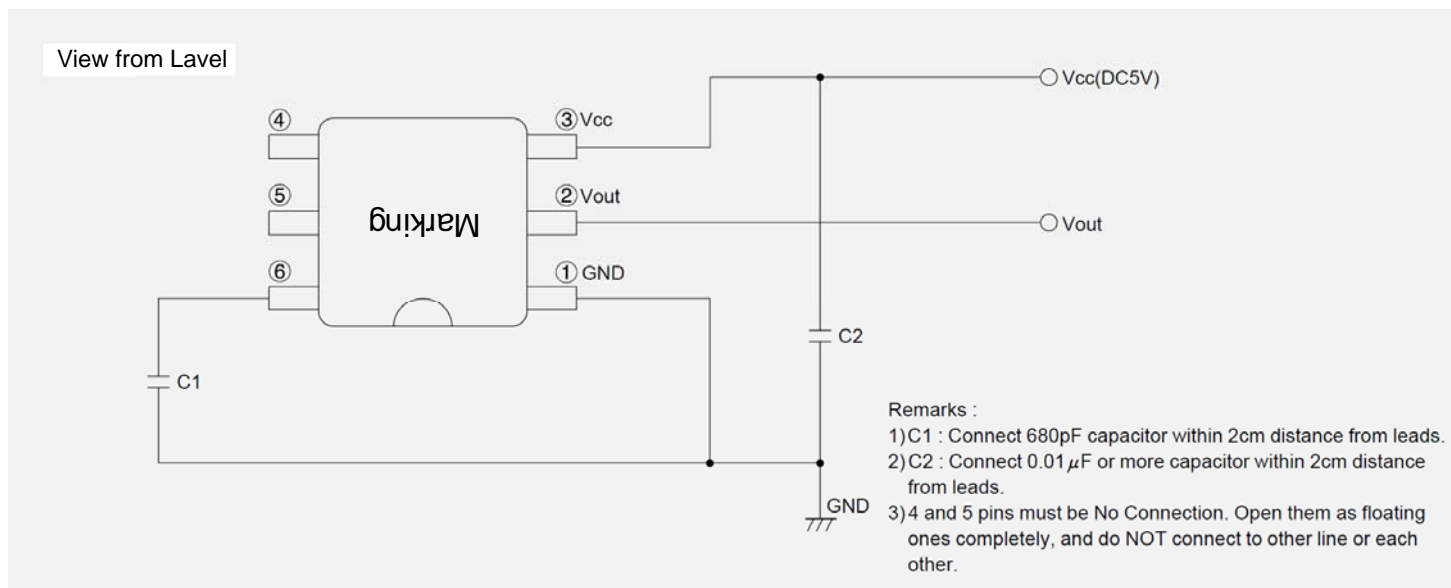

■ Transfer Function ■

$$V_{out} = V_s \times (P \times \alpha + \beta) \pm (\text{Pressure Error} \times \text{Temperature Error Multiplier} \times \alpha \times V_s)$$

$$V_s = V_{cc} = 5.0V$$

$$P = \text{Input pressure (kPa)}$$

Model		Measurable pressure range(kPa)	$\alpha$	$\beta$	Pressure Error (kPa)
XFPM-100KPGW	XFPM-100KPGWR	-100~100	0.0045	0.49	5
XFPM-100KPGV	XFPM-100KPGVR	0~-100	-0.008	0.04	2.5
XFPM-025KPG	XFPM-025KPGR	0~25	0.036	0.04	0.625
XFPM-050KPG	XFPM-050KPGR	0~50	0.018	0.04	1.25
XFPM-100KPG	XFPM-100KPGR	0~100	0.009	0.04	2.5
XFPM-200KPG	XFPM-200KPGR	0~200	0.0045	0.04	5
XFPM-001MPG	XFPM-001MPGR	0~1000	0.0009	0.04	25

Temperature Error Multiplier

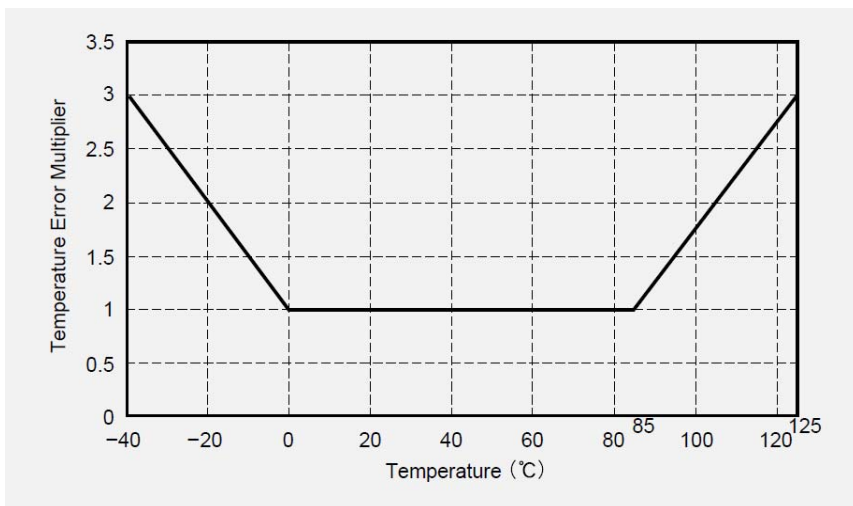

■ Output characteristics ■

XFPM-100KPGV	XFPM-100KPGVR
XFPM-025KPG	XFPM-025KPGR
XFPM-050KPG	XFPM-050KPGR
XFPM-100KPG	XFPM-100KPGR
XFPM-200KPG	XFPM-200KPGR
XFPM-001MPG	XFPM-001MPGR

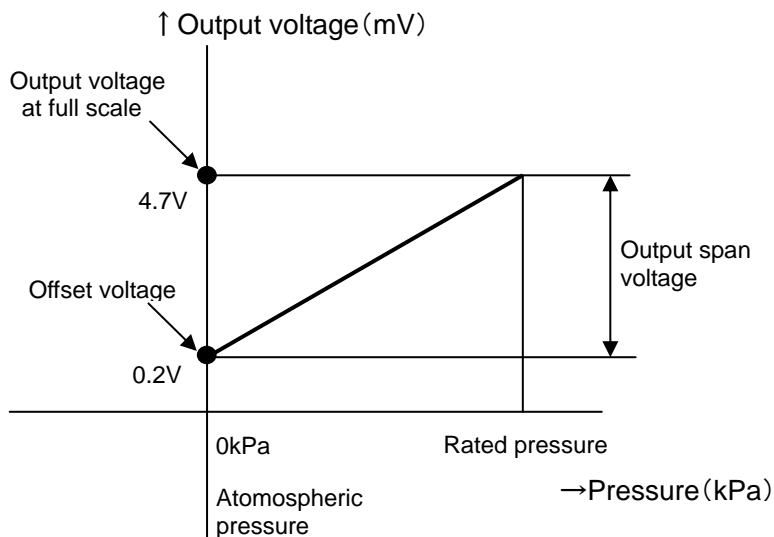

XFPM-100KPGW	XFPM-100KPGWR
--------------	---------------

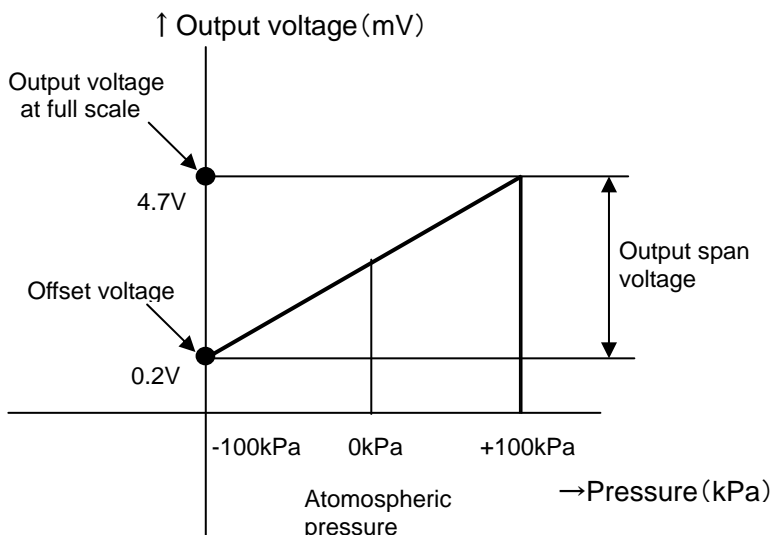

Note ; Please read instruction “Notes” before using the sensor.  
 Fujikura reserves the right to change specifications without notice.

If you have any questions regarding technical issues or specifications, please contact us.  
 Sensor Engineering Department 5-1 Kiba 1-chome, Koto-ku, Tokyo 135-8512, Japan  
 Phone +81-(0)3-5606-1072  
 E-mail : [sensor@fujikura.co.jp](mailto:sensor@fujikura.co.jp)