

1 Scope

The standard enclosed (E) type transducers can be used for outdoor installation, or, because of its special dust-proof construction, can be used in a dusty atmosphere. The transducers consist of a metal housing with integral metal diaphragm, which operate at resonance on the first harmonic overtone. The backs of transducers are completely sealed with resin protecting from exposure the environment.

2 Part Number

400ET25U / 400ER25U Standard Enclosed Type Air Ultrasonic Transducer

3 Dimension

As per Figure 1

4 Specification

(rated at temperature $25\pm 3^{\circ}\text{C}$, 45 to 60% RH, unless otherwise noted)

Model Number: 400ET25U			
	Items	Specification	Remarks
4-1	Center Frequency (Fc)	40KHz \pm 1KHz	HP4192A Impedance analyzer
4-2	Sound Pressure Level	115dB (min)	at Fc; 0dB re 0.0002 μ bar per 10Vrms at 30cm 10Vrms sine wave input detail see attached Figure 2
4-3	Bandwidth	1.0KHz (min)	-6dB
4-4	Capacitance	2800pF	\pm 20%, measured at 1KHz
4-5	Total Beam Angle	35° (TYP.)	-6dB Main Beam
4-6	Operation Temperature	-30°C to +70°C	
4-7	Storage Temperature	-40°C to +80°C	
Model Number: 400ER25U			
	Items	Specification	Remarks
4-8	Center Frequency (Fc)	40KHz \pm 1KHz	HP4192A Impedance analyzer
4-9	Sensitivity	-68dB (min)	at Fc; 0dB=1Volt/ μ bar detail see attached Figure 3
4-10	Bandwidth	1.0KHz (min)	-6dB
4-11	Capacitance	2800pF	\pm 20%, measured at 1KHz
4-12	Operation Temperature	-30°C to +70°C	
4-13	Storage Temperature	-40°C to +80°C	

5 Environmental Characteristics

- 5-1 Overall echo sensitivity shall not change by more than $\pm 3\text{dB}$ in the temperature range of -30°C to 70°C , at a relative humidity of $\pm 50\%$
- 5-2 Overall echo sensitivity shall not change by more than $\pm 3\text{dB}$ in the humidity range of 10% to 90% at the temperature of 25°C
- 5-3 Overall echo sensitivity shall be within $\pm 3\text{dB}$ of the specified values after the device is subjected to any or all of the below
 - 5-3-1 Operation at 90% relative humidity and 40°C for 100 hours, followed by a normalization period of 24 hours at 30% and 25°C
 - 5-3-2 Storage at -40°C to $+80^{\circ}\text{C}$ for 24 hours followed by a normalization period of an hour at 25°C
 - 5-3-3 Vibration at 10 to 55Hz, 1.5mm amplitude. 1 minute sweep. X, Y, Z, 3 each axis for 3 hours.
 - 5-3-4 Shock: After impact of 50G is applied following. X, Y, Z, 3 axis /3 cycle / each direction.

6 Mechanical Characteristics

Lead strength

To pull longitudinally 1.0 kgf min.

To push longitudinally 1.0 kgf min.

7 Warranty

- 7-1 Warranty period is one year after delivery
- 7-2 Defective transducers attributable to manufacturer's responsibility shall be replaced for free, during the warranty period. However, following cases are out of the this replacement.
 - 7-2-1 Unsuitable handling or misuse by user.
 - 7-2-2 Modification or repair by user.
 - 7-2-3 Any other cases not responsible for manufacturer such as natural calamity, accident, etc.

This warranty covers only replacement. Any loss derived from failure or malfunction of the transducer, or cost to replace is excluded from this warranty.

Dimensions: unit mm

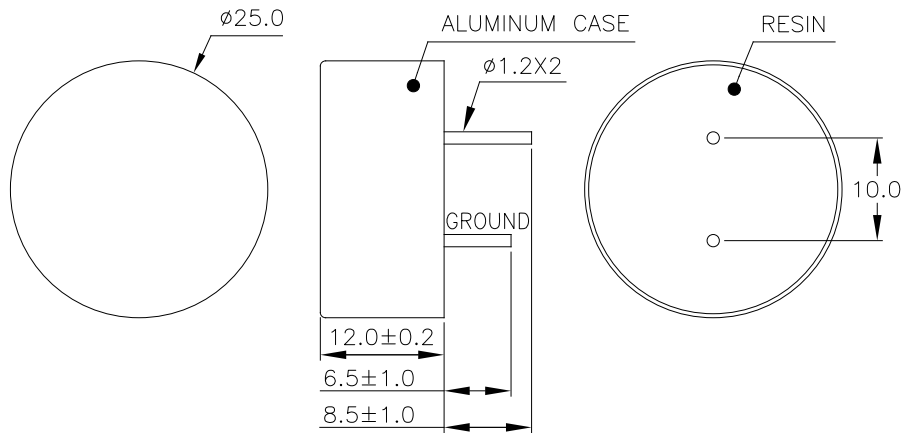

Figure 1

Sound Pressure Level measuring system:

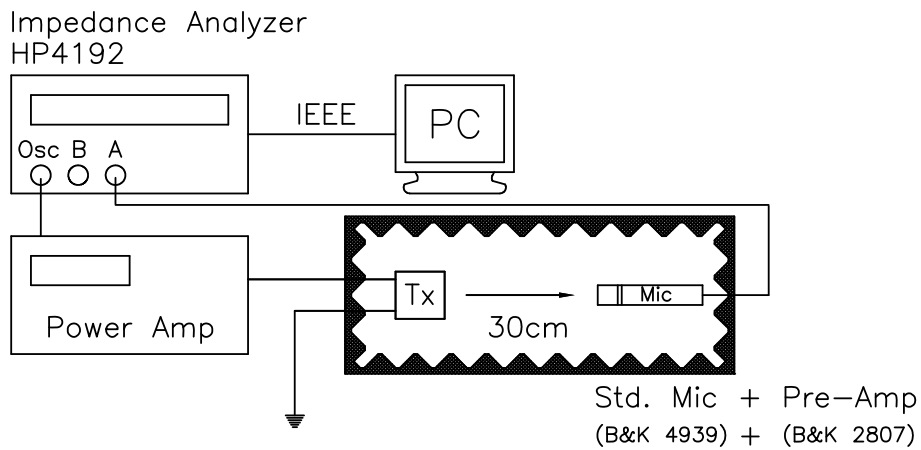

Figure 2

Sensitivity measuring system:

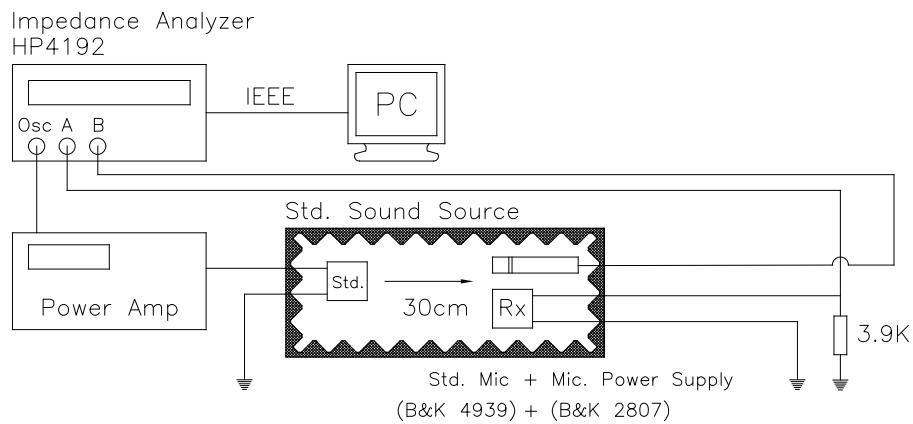

Figure 3