

AQ70Z SENSOR

Ozone (O₃) Gas Sensor

DOCUMENT PURPOSE

The purpose of this document is to present the performance specification of the AQ7 Series AQ70Z Ozone Gas Sensor.

This document should be used in conjunction with the AQ70Z Characterization Note and the Product Safety Datasheet (PSDS 5.4). For guidance on the safe use of the sensor, please refer to the Characterization Note.

The data provided in this document is based on the assumption that the sensor is used at 20°C, 50 %RH and 1013 mBar for three months from the date of sensor manufacture.

APPLICATIONS

The AQ7 Series are for environmental applications; other applications, including industrial safety, may not be suitable.



Sensor Part Number: ASQ704-400

FEATURES AND BENEFITS



High resolution



Low detection limit



Independent NO₂
cross compensation by
using 4th electrode

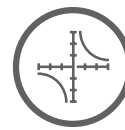

High correlation with
control station



Individual compensation
for temperature and
cross sensitivity

AQ7OZ Ozone Gas Sensor

TECHNICAL SPECIFICATIONS	
MEASUREMENT	
Technology	4-electrode electrochemical
Measurement Range	0 ppm O ₃ to 1 ppm O ₃
Maximum Overload	5 ppm O ₃
Sensitivity*	500 nA/ppm ±200 nA/ppm
Response Time (T₉₀)	≤ 120 seconds
Resolution* (when using recommended electronics)	5 ppb
Baseline Offset*	<±100 nA
Repeatability*	< ±5 % of signal
Linearity**	linear
Low Detection Limit*	5 ppb
ELECTRICAL	
Recommended Load Resistor	68 Ω
Sensor Bias Voltage	0 mV
MECHANICAL	
Weight	9 g
Outer Plastic Body Material	ABS
Contact Material	copper with gold coating
Orientation Sensitivity	none
ENVIRONMENTAL	
Operating Temperature Range	-30°C to 50°C (55°C intermittent***)
Operating Humidity Range	15 %RH to 90 %RH non-condensing
Recommended Storage Temperature	0°C to 20° in original sealed container
Typical Applications	ambient environmental monitoring
LIFETIME	
Storage Life	6 months in original sealed container
Long-Term Sensitivity Drift*	< 10 % signal loss per annum
Expected Operating Life	two years in air
Warranty	one year

*Specifications are based on measurements made with cylinder gases using a flow rate of 500 ml/min and are valid at 20°C, 50 %RH and 1013 mBar using Honeywell recommended circuitry. Performance characteristics outline the performance of sensors supplied within the first three months. Output signal can drift below the lower limit over time.

** Linear through the concentration range across the whole operational environment range.

*** Can be operated at 55°C for two hours (within the operating humidity range).

Product Dimensions

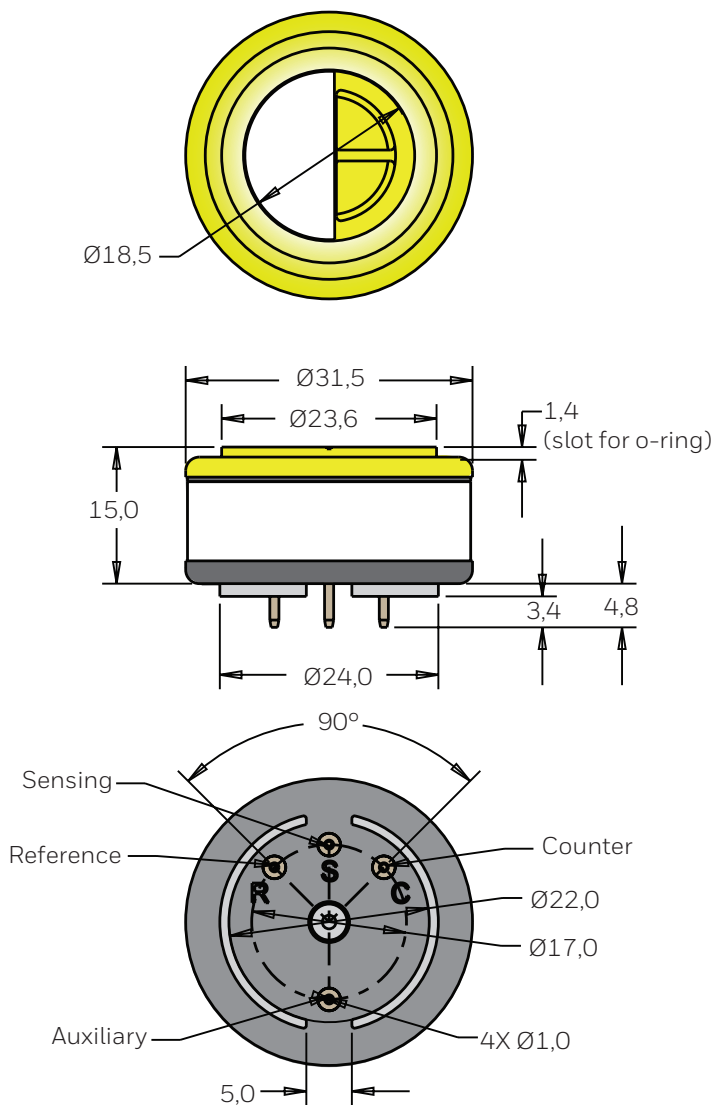

Dimensions mm
All tolerances ±0,15 mm unless otherwise stated

AQ7OZ Ozone Gas Sensor

Poisoning

Gas sensors are designed for operation in a wide range of environments and harsh conditions. However, it is important that exposure to high concentrations of solvent vapors is avoided, during storage, fitting into instruments, and operation.

When using sensors with printed circuit boards (PCBs), degreasing agents should be used before the sensor is fitted.

Do not glue directly on or near the sensor as the solvent may cause crazing of the plastic.

Cross Sensitivity Table

Whilst AQ7 Series gas sensors are designed to be highly specific to the gas they are intended to measure, they will still respond to some degree to various other gases. The table below is not exclusive and other gases not included in the table may still cause a sensor to react.

IMPORTANT NOTE: The cross sensitivity data shown below does not form part of the product specification and is supplied for guidance only. Values quoted are based on tests conducted on a small number of sensors and any batch may show significant variation. For the most accurate measurements, an instrument should be calibrated using the gas under investigation.

Gas	Gas Concentration	Cross Interference
Carbon Monoxide (CO)	5 ppm	0 % < X % < 1 %
Nitrogen Dioxide (NO ₂)	5 ppm	0 % < X % < 15 % (after compensation)
Hydrogen Sulfide (H ₂ S)	5 ppm	0 % < X % < 150 %
Sulfur Dioxide (SO ₂)	5 ppm	0 % < X % < 1 %
Isobutylene (C ₄ H ₈)	5 ppm	None

WARRANTY/REMEDY

Honeywell warrants goods of its manufacture as being free of defective materials and faulty workmanship during the applicable warranty period. Honeywell's standard product warranty applies unless agreed to otherwise by Honeywell in writing; please refer to your order acknowledgment or consult your local sales office for specific warranty details. If warranted goods are returned to Honeywell during the period of coverage, Honeywell will repair or replace, at its option, without charge those items that Honeywell, in its sole discretion, finds defective. **The foregoing is buyer's sole remedy and is in lieu of all other warranties, expressed or implied, including those of merchantability and fitness for a particular purpose. In no event shall Honeywell be liable for consequential, special, or indirect damages.**

While Honeywell may provide application assistance personally, through our literature and the Honeywell web site, it is buyer's sole responsibility to determine the suitability of the product in the application.

Specifications may change without notice. The information we supply is believed to be accurate and reliable as of this writing. However, Honeywell assumes no responsibility for its use.

FOR MORE INFORMATION

Honeywell Advanced Sensing Technologies services its customers through a worldwide network of sales offices and distributors. For application assistance, current specifications, pricing or the nearest Authorized Distributor, visit our [website](#) or call:

USA/Canada	+1 302 613 4491
Latin America	+1 305 805 8188
Europe	+44 1344 238258
Japan	+81 (0) 3-6730-7152
Singapore	+65 6355 2828
Greater China	+86 4006396841

Honeywell Advanced Sensing Technologies

830 East Arapaho Road
Richardson, TX 75081
sps.honeywell.com/ast

WARNING MISUSE OF DOCUMENTATION

- The information presented in this product sheet is for reference only. Do not use this document as a product installation guide.
- Complete installation, operation, and maintenance information is provided in the instructions supplied with each product.

Failure to comply with these instructions could result in death or serious injury.

SAFETY NOTE

This sensor is designed to be used in environmental applications. To ensure that the sensor and/or instrument in which it is used, are operating properly, it is a requirement that the function of the device is confirmed by exposure to target gas (bump check) before each use of the sensor and/or instrument. Failure to carry out such tests may jeopardize the safety of people and property.