

## General

V 1.21

T-300A series is series is one of world lowest and smallest dimension CO<sub>2</sub> sensor miniature. Its consistent stability with easy management are much favored by customers in residential buildings, offices, or cabin of vehicles, or so.

---

# ELT Sensor Data Sheet for T-300A

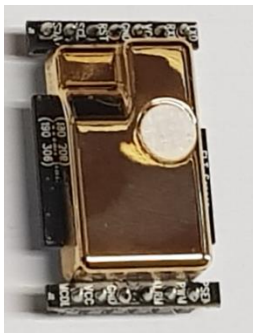

## Features

- Non-Dispersive Infrared (NDIR) technology used to measure CO<sub>2</sub> levels.
- World's lowest height miniature
- Available output : TTL-UART, I2C
- Gold-plated sensor provides long-term stability.
- Calibration functions : ACDL (Periodical Automatic Calibration) is default.
- Size : 19mm x 31mm x 8.2mm (W,L,H)
- Weight : 5 grams

## T-300A Specifications

### General Performance

**Operating Temperature** : -10℃ ~ 60℃

**Operating Humidity** : 0 ~ 95% RH (Non-condensing)

**Operating Environment** : Residential, Commercial spaces

**Storage Temperature** : -30℃~70℃

### CO<sub>2</sub> Measurement

**Sensing Method** : NDIR (Non-dispersive Infrared)

**Measurement Range** : 400 ~ 5,000ppm

(400~2,000/3,000/10,000ppm can be chosen as option)

**Accuracy** : ± 75ppm ± 3%of reading <sup>(1)(2)</sup>

**Response Time(1/e)** : 90 seconds

**Signal Update** : 5 seconds

**Warming-up Time** : < 10 seconds (for Operation), < 5 minutes (for Accuracy)

### Electrical Data

**Power Input** : 5.0VDC ± 5%<sup>(3)</sup> (4.75~5.25VDC)

**Current Consumption**: I<sub>avr</sub> < 9mA, I<sub>peak</sub> < 220 mA

### Pin-Map of J1 : Left Side-holes.

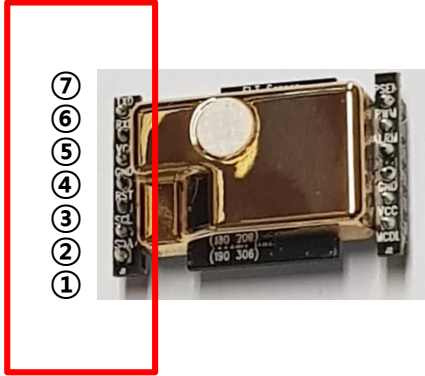
Pin No.	T-300A	J1 : Left side hole
1	I2C SDA	
2	I2C SCL	
3	/Reset	
4	GND	
5	VCC	
6	TTL-RXD( ← CPU of Master Board )	
7	TTL-TXD( → CPU of Master Board )	

<sup>(1)</sup> IAQ application, accuracy is defined after minimum 3 times calibration for 3 weeks.

<sup>(2)</sup> +/- 2% is added for absolute measurements for uncertainty of calibration gas mixture unless the measurement is done with certified calibration mixtures.

<sup>(3)</sup> DC Supply should be regulated, low noise power source for best accuracy.,

**Pin-Map of J2 : Right Side-holes.**

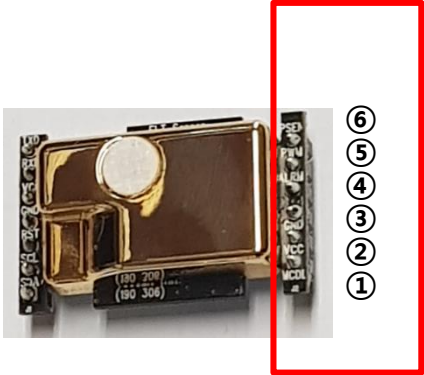
Pin No.	T-300A	J2 : Right Side-holes
1	MCDL (10 min. Manual Calibration)	
2	VCC	
3	GND	
4	Alarm (5V/0V switching)	
5	PWM	
6	Reserved (/PSEN)	

**UART**

38,400BPS, 8bit, No parity, 1 stop bit, TTL Level Voltage

**I2C**

Slave mode only, Pull up resistor 10kohm is needed on Main-board.

Digital I/O Level Voltage :  $0 \leq V_{IL} \leq 0.5$ ,  $2.0 \leq V_{IH} \leq V_{DD}$ ,  $0 \leq V_{OL} \leq 0.6$ ,  $2.7 \leq V_{OH} \leq V_{DD}$  (Volt)

**PWM** : Option.

$t_H = 2 \text{ msec(Start)} + 1,000 \text{ msec} \times (\text{Measurement}_{(\text{ppm})} / \text{Range}_{(\text{ppm})})$ ,

$t_L = 2,000 \text{ ppm} - t_H$ , (Period : 2,000 ppm)

**Alarm** : Optional (Protection Circuit to prevent from sensor to main-board is essential.)

1200 ppm  $\leq$  On (High), 800 ppm  $\geq$  Off (Low)

Dimensions (mm)

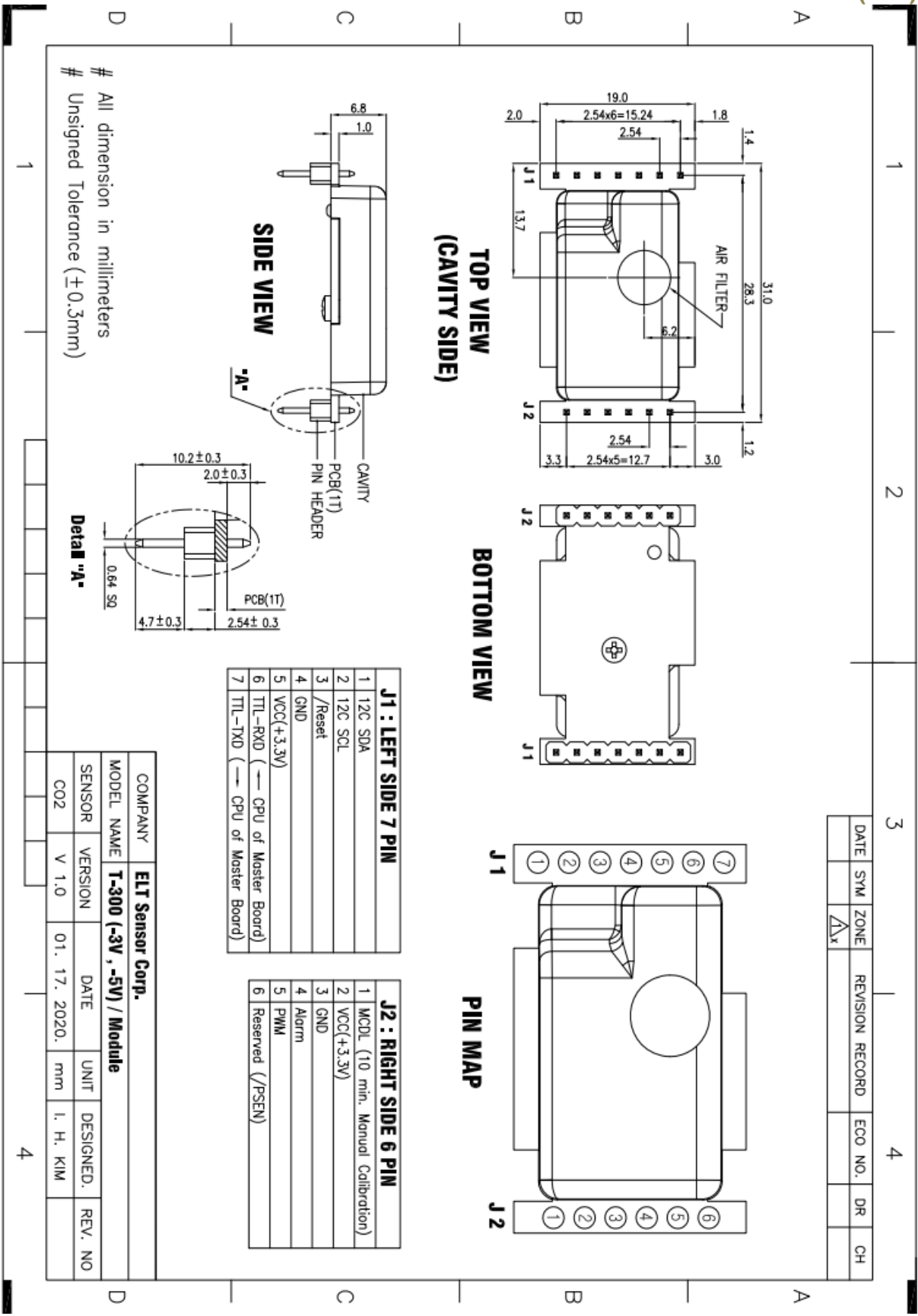

DATE	SYM	ZONE	REVISION RECORD	ECO NO.	DR	CH

J1 : LEFT SIDE 7 PIN	
1	12C SDA
2	12C SCL
3	/Reset
4	GND
5	VCC(+3.3V)
6	TTL-RXD ( ← CPU of Master Board)
7	TTL-TXD ( ← CPU of Master Board)

J2 : RIGHT SIDE 6 PIN	
1	MODL (10 min. Manual Calibration)
2	VCC(+3.3V)
3	GND
4	Alarm
5	PWM
6	Reserved (/PSEN)

# All dimension in millimeters  
 # Unsigned Tolerance (±0.3mm)

COMPANY	ELT Sensor Corp.					
MODEL NAME	T-300 (-3V, -5V) / Module					
SENSOR VERSION	DATE	UNIT	DESIGNED.	REV.	NO	
CO2	V 1.0	01. 17. 2020.	mm	I. H. KIM		

Dimensions (mm)

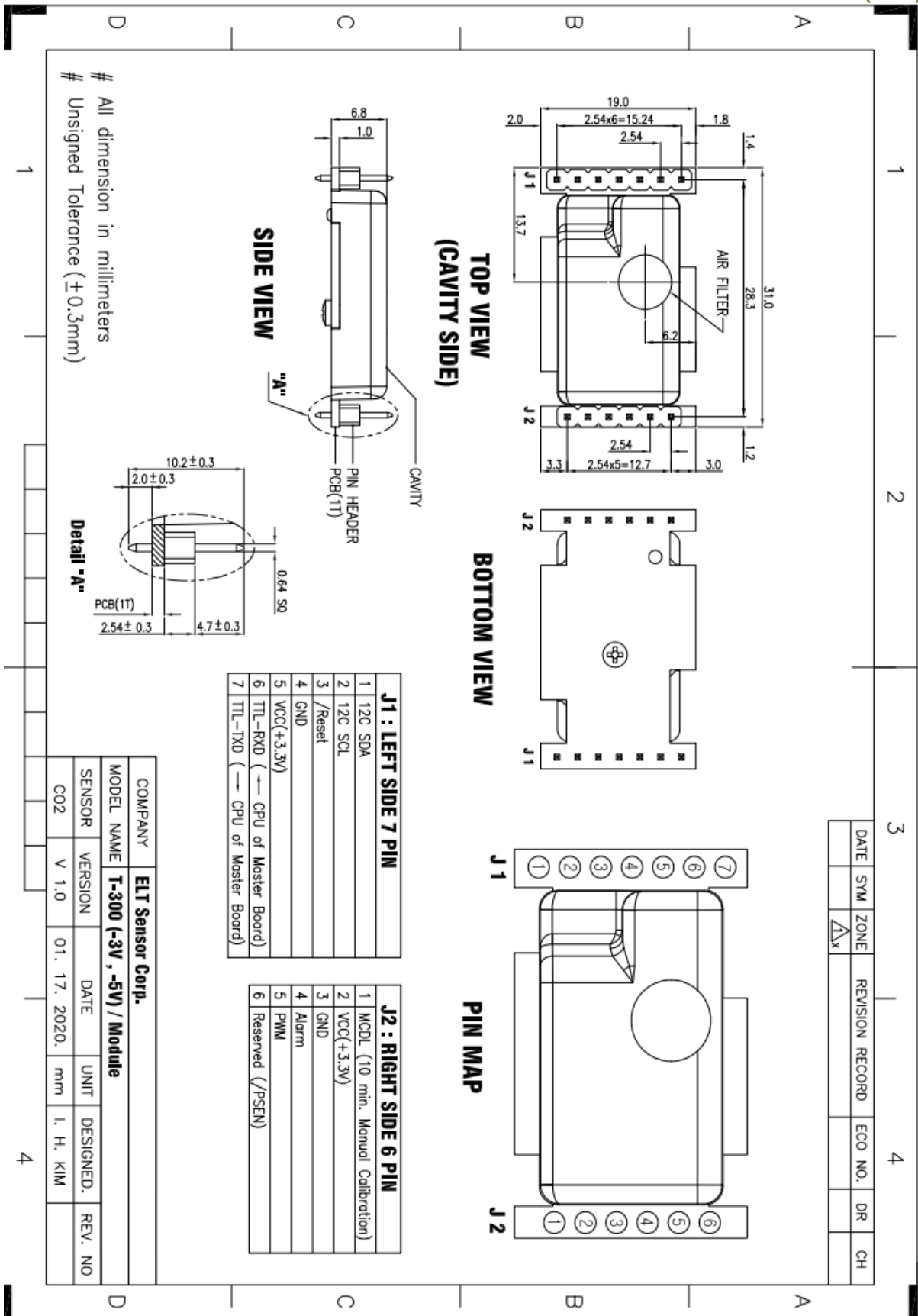

**ACDL function(Automatic Calibration Function in Dimming light with period)**

; start as default when powered on. T-300A-3V always operate as ACDL unless MCDL is activated.

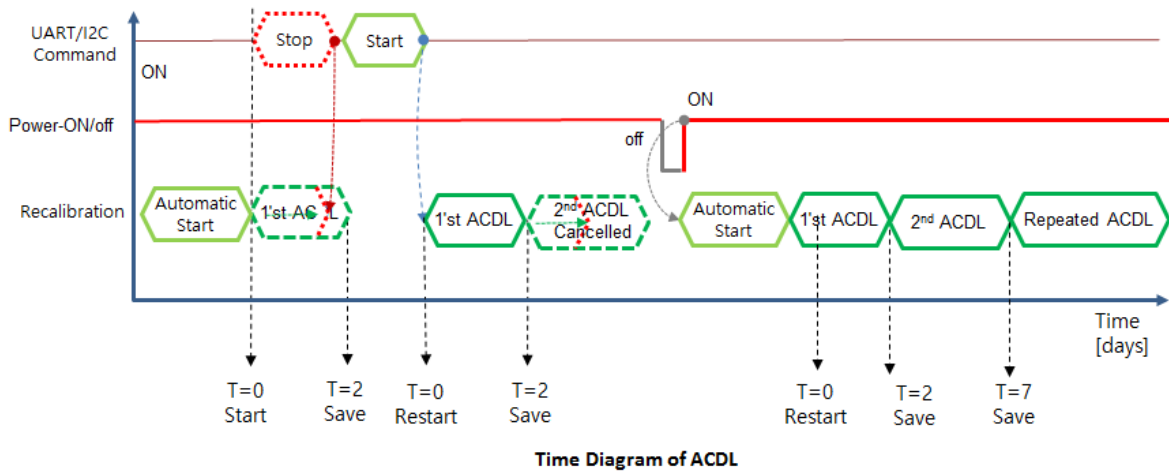

Method 1. UART Command Set; J1-6pin (UART-RX) & J1-7pin (UART-TX) to Main-Board.

Method 2. I2C Command Set; J1-1pin (SDA) and J1-2pin (SCL) to Main-Board.

**10' MCDL function(10 minute Manual Calibration Function in Dimming light)**

MCDL enable customer to calibrate as needed, MCDL keep at least 10 minute once it start and should be stopped before 18minute to avoid MCDL fetch repetition.

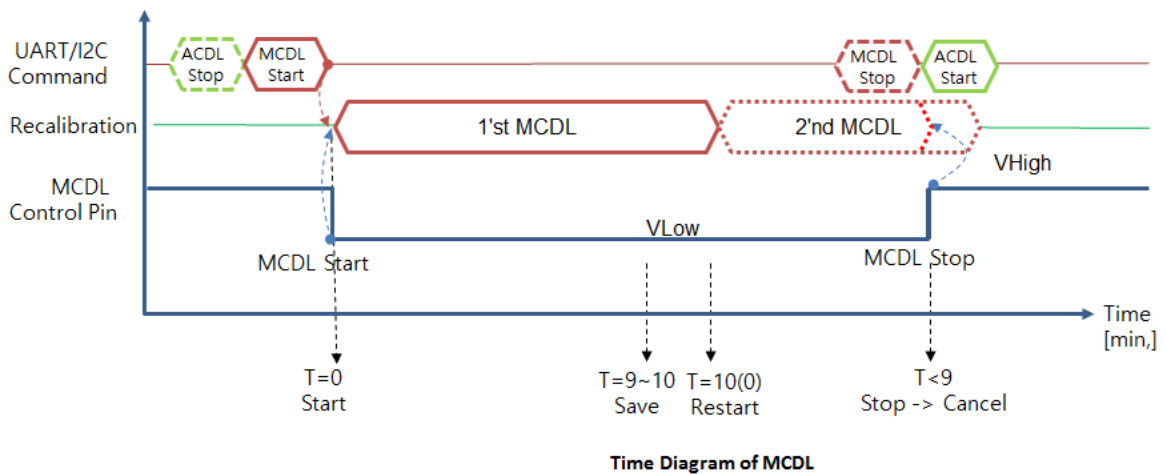

Method 1. UART Command Set; J1-6pin (UART-RX) and J1-7pin (UART-TX) to Main-Board.

Method 2. I2C Command Set; J1-1pin (SDA) and J1-2pin (SCL) to Main-Board.

Method 3. MCDL Control-pin is available.

## Output Descriptions

### UART Descriptions

Data Format

D6	D5	D4	D3	D2	D1	SP	'p'	'p'	'm'	CR	LF
----	----	----	----	----	----	----	-----	-----	-----	----	----

D6 ~ D1	6 byte CO2 density string
SP	Space: 0x20
'ppm'	'ppm' string
CR	Carriage return : 0x0D
LF	Line feed : 0x0A

Above 12byte consist by 6 byte hexadecimal digits,<SP>,0x70 0x70 0x6D, <CR><LF> , where decimal '0' (corresponds to hexadecimal digit '0x30') is replaced by space (corresponds to hexadecimal digit '0x20'),

EX) 1,255 ppm, results '0x20 0x20 0x31 0x32 0x35 0x35 0x20 0x70 0x70 0x6D 0x0D 0x0A', which displays '\_1255\_ppm<CR><LF>'on screen.

In need of detail command set, 'U-ART String Command Guide ' could be provided by contacting Sales Rep.

### I2C Communication (Only Slave Mode Operation)

Internal pull up resister

Slave Address: 0x31, Slave Address Byte: Slave Address(0x31) 7 Bit + R/W 1 Bit

Bit7	Bit6	Bit5	Bit4	Bit3	Bit2	Bit1	Bit0
0	1	1	0	0	0	1	R/W Bit

R/W Bit : Read = 1/Write = 0

When reading the data, Slave Address Byte is 0x63, When writing the data, Slave Address Byte is 0x62.

**Block Diagram**

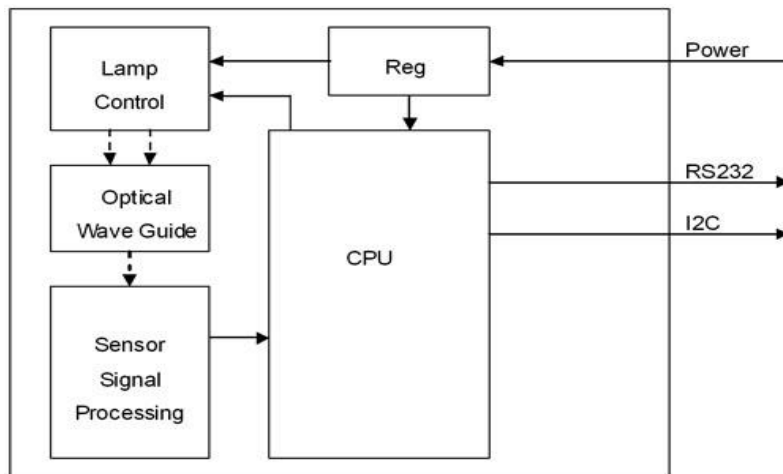

**Transmission Sequence in Master**

- 1) I2C Start Condition
- 2) Write Command(Slave Address + R/W Bit(0) = 0x62) Transmission and Check Acknowledge
- 3) Write Command(ASCII 'R' : 0x52) Transmission and Check Acknowledge
- 4) I2C Stop Command
- 5) I2C Start Command
- 6) Read Command(Slave Address + R/W Bit(1) = 0x63) Transmission and Check Acknowledge
- 7) Read 7 Byte Receiving Data from Module and Send Acknowledge  
(Delay at least 1ms for reading each byte)

Configuration	CO <sub>2</sub>	reserved	reserved	reserved	reserved
1 Byte	2 Byte	0x00	0x00	0x00	0x00

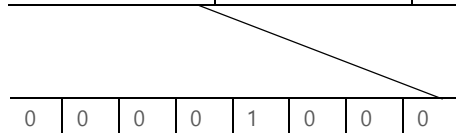

In need of detail protocol specification and time sequence, 'I2C programming guide' could be provided by contacting Sales Rep.

**PWM Descriptions (Option)**

\* Measurement<sub>(ppm)</sub> = (t<sub>H</sub>-2msec)/1000msec x Range<sub>(ppm)</sub> (t<sub>H</sub> : High Pulse Width)

\* Range<sub>(ppm)</sub> : 0~2,000 (0~5,000ppm is option)



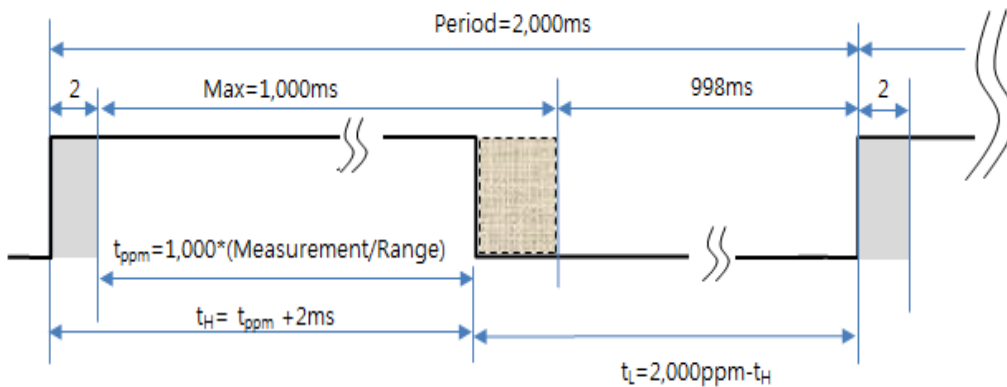

EX)  $t_H$ (High Pulse Width) calculation for 400ppm in 2,000 ppm Range.

\* $Measurement_{(ppm)} = 400 \text{ ppm} = (t_H - 2\text{ms}) / 2,000\text{msec} \times Range_{(ppm)}$  ,

\* $t_H = 1,000 \text{ msec} * (400 \text{ ppm} / 2,000\text{ppm}) + 2\text{msec} = 202\text{msec}$

(cf:  $T_L = \text{Period} - t_H = 2,000\text{ppm} - 202 \text{ msec} = 1,798 \text{ msec.}$ )

### Alarm Descriptions (Option)

Protection Circuit to prevent reverse direction current from sensor to main-board is essential.

1200 ppm ≤ On (High), 800 ppm ≥ Off (Low)

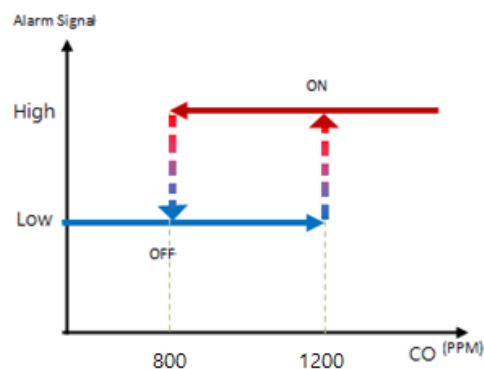

### ※ Caution

1. Please hold only 'PCB' of sensor without holding Cavity directly to avoid the physical shock on sensor. Rough handling or Transportation could result in inaccurate reading.
2. Proper ESD protection during handling is important to avoid electrostatic defect occurrence.  
The storage of sensor should be insulated as well



ChunuiTechnopark 101-910) 36,  
Bucheon-ro 198beon-gil, 2015  
Wonmi-gu, Bucheon-si, Gyeonggi-do, 420-857, Korea  
Phone. +82-32-719-8055, <http://www.eltensor.co.kr>

Subject to change without notice. Printed in KOREA  
ELT Sensor All rights reserved.

2019. March