

General

Ver 1.15

S-110H(G) series are upgraded version from and compatible with S-110H which operates with 12VDC. Its enforced persistency and stability with wider voltage tolerance are much favored by harsh applications of Livestock raising, plant growing, scientific projects. S-110HA lowered height for customers' thinner design besides easier management for ventilation application from wall pads at car, buildings, schools and offices and so on.

Carbon Dioxide (CO₂)Module

Model : S-110H(G)

**Features**

- Non-Dispersive Infrared (NDIR) technology used to measure CO₂ levels.
- Pre-calibrated
- Available outputs : TTL-UART, I2C, Analog Voltage or PWM is optional
- Gold-plated sensor provides long-term calibration stability.
- Installed Calibration function
- Operate as ACDL mode (Automatic Calibration in Dimming Light mode).
- 10 minute Manual Re-Calibration function is available as default.
- Size: 39mmx32mmx13mm
(lead height excluded)
- Weight: 10g

S-110H(G) Specifications

General Performance

Operating Temperature range : -10~ 60°C

Operating Humidity range : 0 ~ 95% RH (Non-condensing), 'G': 0 ~ 99% RH (Non-condensing) ⁽¹⁾

Storage Temperature : -30°C ~70°C

CO₂ Measurement

Sensing Method : NDIR (Non-dispersive Infrared)

Measurement Range : 0 to 2,000/3,000/5,000/10,000 ppm

Accuracy : ±50ppm ±3%⁽²⁾⁽³⁾

Response Time(90%) : 90 seconds

Sampling Interval : 3 seconds

Electrical Data

Input Power : 12VDC (9~18VDC, ±10% Regulation) ⁽⁴⁾

Power Consumption : Normal(14mA), Max(145mA) at lamp on peak

Output connector : 11 pin header connector (2.54mm pitch, 4mm height)

Output Signal

UART : 38,400BPS, 8bit, No parity, 1 stop bit TTL Level

I2C : Slave mode only, Internal pull up resister, Under 30kHz Clock

TTL Level Voltage : $0 \leq V_{IL} \leq 1.2$, $3.5 \leq V_{IH} \leq 5.0$ (Volt), $0 \leq V_{OL} \leq 0.4$, $4.2 \leq V_{OH} \leq 5$ (Volt)

PWM (Option)

Analog Voltage (option) : VDC 0.5 ~ 4.5V

Product Derivatives and Relative Functions

Products	Option List
S-110HG	Resistant up to 0~99% RH Humidity for application of Green house etc.
S-110HA (ACDL S/W)	Periodic Automatic Calibration Software is added on S-110(G).

S-110H is upgraded to enable customer to have PWM Output for pin-10. (Factory option)

S-110HA is developed to have ACDL software to be installed in sensor, enabling customer to omit the connection to pin-11.

(1) S-110H(G): 0 ~ 99% RH (Non-condensing) for Application of Green House

(2) Air pressure is assumed as 101.3 kPa..

(3) If sensor is affected by the shock, may need field calibration before installation.

(4) DC Supply should be regulated without ripple < 100mV, low noise power source is needed for best accuracy.

Pin Description for S-110H

J12pin	S-110H(G)	S-110HA (ACDL)
1	I2C SDA	
2	I2C SCL	
3	12VDC Power Supply	
4	Reset (Low Active)	
5	Reserved (Should Not connect)	
6	GND	
7	TXD (UART)	
8	RXD (UART)	
9	MCDL-pin (10 min. Manual Calibration)	
10	Analog Voltage Output (PWM is Optional) – Factory setting by Order	
11	ACDL-pin (Automatic Calibration)	Should be kept 'High' or disconnected

Dimensions (unit : mm)

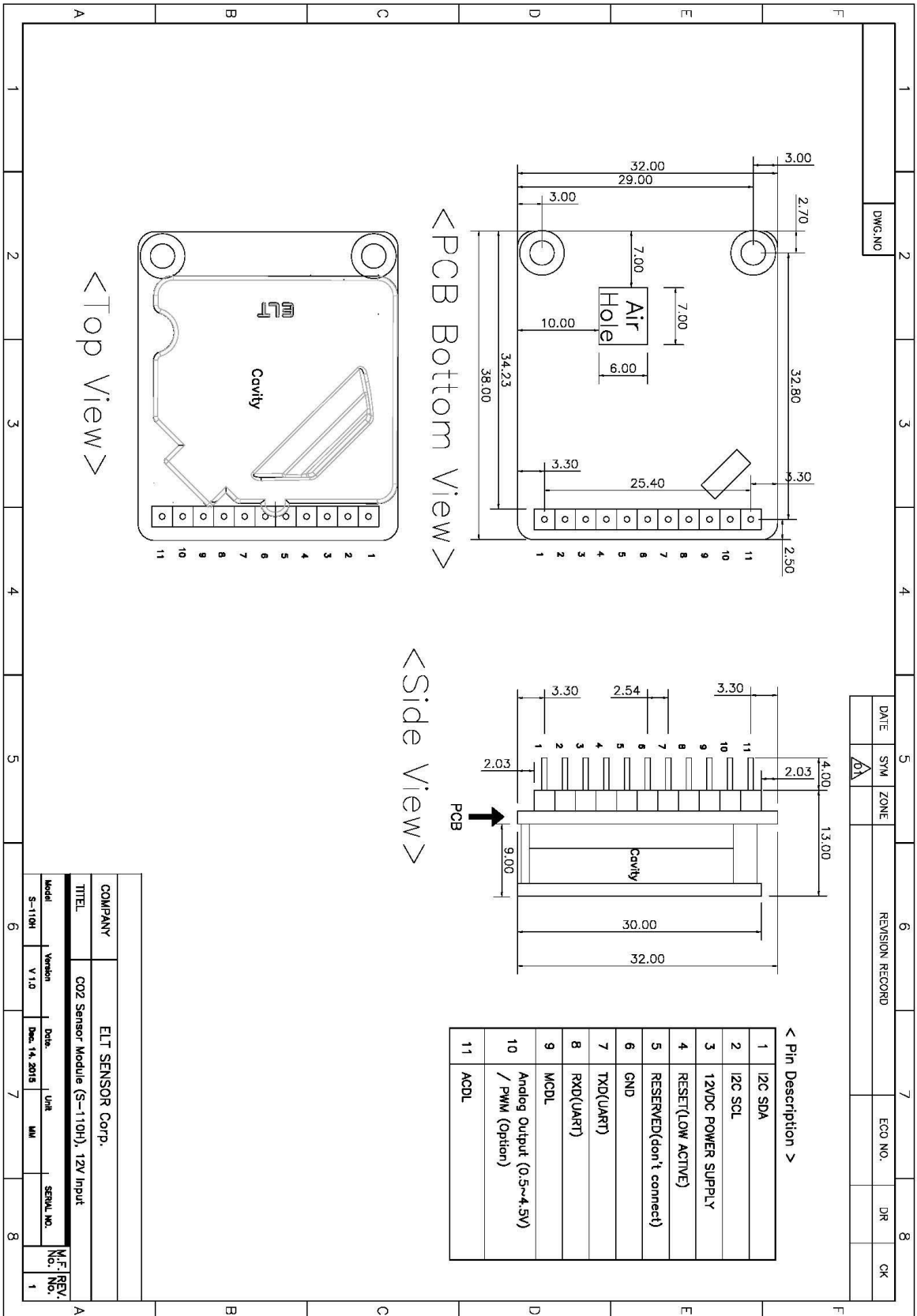

COMPANY	ELT SENSOR Corp.			
TITLE	CO2 Sensor Module (S-110H), 12V Input			
Model	Version	Date	Unit	Serial No.
S-110H	V 1.0	Dec. 14, 2018	MM	
M.F. REV. No.				1

ACDL function (Automatic Calibration Function in Dimming light with period)

ACDL could be activated as by setting below.

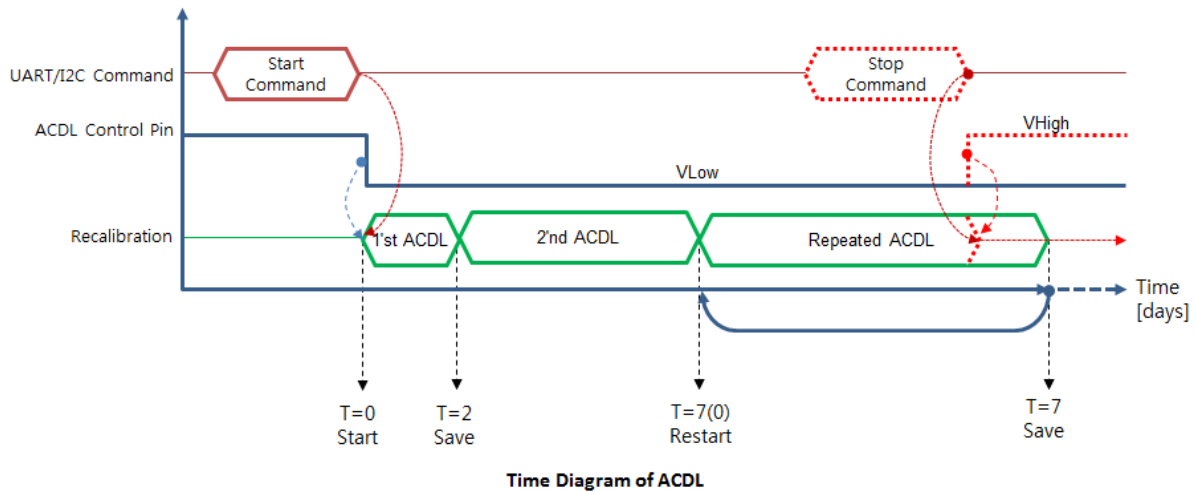

Method 1. UART Command Set; J12: pin-8 (UART-RX) and pin-7 (UART-TX) to Main-Board.

Method 2. I2C Command Set; J12: pin-2 (SCL) and pin-1 (SDA) to Main-Board.

Method 3. Execute Hardware based ACDL.

J12:pin-11	J12:pin-9	Status	Notes
Low	High	H/W ACDL	Calibrate weekly after 2 days since power-on
High	High	Normal	Operate with Pre-calibrated value in Factory or previous state.

※ 1. (J12:pin-11) and (J12:pin-9) shouldn't have 'Low' at any time.

Cf.) Unlike other S-110H(G) series, S-110HA operate with software based ACDL setting, which make sensor always operate with ACDL as default unless MCDL is activated.

Method 4. **TRB-100ST (Test and Recalibration Board)** is purchasable to executable, letting sensor be located at ambient air-flow condition and execute by moving jumper following Manual, which is downloadable on the website.

Method 5. Send string command set below to RXD-pin of Sensor on Emulation program.

EK-100SL (Evaluation kit, with Emulation program 'ELTWSO') is available.

10' MCDL function (10 minute Manual Calibration Function in Dimming light)

MCDL enable customer to calibrate as needed, MCDL keep at least 10 minute once it start and should be stopped before 18minute to avoid MCDL fetch repetition.

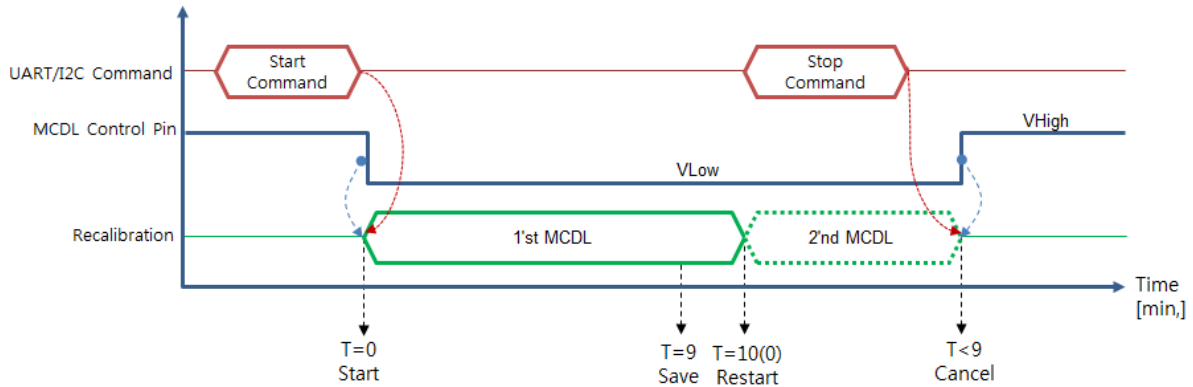

Time Diagram of MCDL

Method 1. UART Command Set; J12: pin-8 (UART-RX) and pin-7 (UART-TX) to Main-Board.

Method 2. I2C Command Set; J12: pin-2 (SCL) and pin-1 (SDA) to Main-Board.

Method 3. Execute Hardware based MCDL.

J12:pin-11	J12:pin-9	Status	Notes
High	Low	H/W MCDL	sensor should be located in 400ppm environment (outside) for 10 minutes
High	High	Normal	Operate with Pre-calibrated value in Factory or previous state.

※ 1. (J12:pin-11) and (J12:pin-9) shouldn't have 'Low' at any time.

2. Be sure to quit MCDL fetch loop before 18minute.

cf.) Unlike other S-110H(G) series, S-110HA has nothing to do with (J12:pin-11).

It is designed to execute MCDL during pin-9 get Low Active Signal and it returns to ACDL as the signal to pin-9 is changed to High De-Active Signal.

Method 4. Let Sensor install on Jig Board, **TRB-100ST (Test and Recalibration Board)** with ambient air-flow condition and execute by moving jumper following Manual on the website.

Method 5. Send string command set below to RXD-pin of Sensor on Emulation program.

EK-100SL (Evaluation kit, with Emulation program 'ELTWSD') is available.

Output Voltage Descriptions

UART Descriptions

Data Transmit

Interval :3 seconds

Handshake protocol : None (Data is transmitted to outer device periodically)

Data Format

D5	D4	D3	D2	D1	SP	'p'	'p'	'm'	CR	LF
----	----	----	----	----	----	-----	-----	-----	----	----

D1 ~ D5	5 byte CO2 density string
SP	Space: 0x20
'ppm'	'ppm' string
CR	Carriage return : 0x0D
LF	Line feed : 0x0A

Above 11byte consist of 5 byte hexadecimal digits,<SP>,0x70 0x70 0x6D, <CR><LF> , where decimal '0' (corresponds to hexadecimal digit '0x30') is replaced by space (corresponds to hexadecimal digit '0x20'),

EX) 1,255 ppm, results '0x20 0x31 0x32 0x35 0x35 0x20 0x70 0x70 0x6D 0x0D 0x0A', which displays '_1255_ppm<CR><LF>'on screen.

I2C Communication (Only Slave Mode Operation)

Internal pull up resistor

Slave Address: 0x31, Slave Address Byte: Slave Address(0x31) 7 Bit + R/W 1 Bit

Bit7	Bit6	Bit5	Bit4	Bit3	Bit2	Bit1	Bit0
0	1	1	0	0	0	1	R/W Bit

R/W Bit : Read = 1/Write = 0

When reading the data, Slave Address Byte is 0x63, When writing the data, Slave Address Byte is 0x62.

Block Diagram

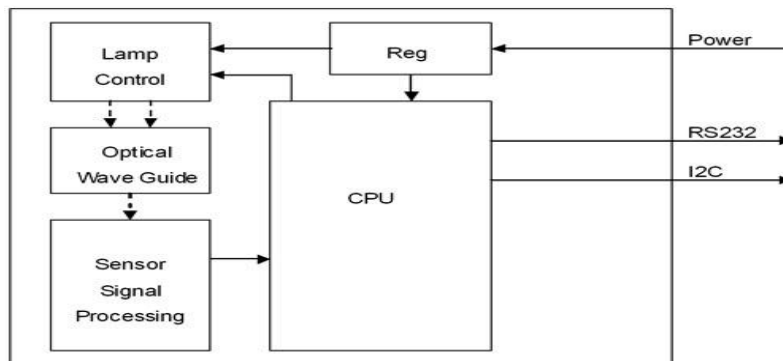

Transmission Sequence in Master

- 1) I2C Start Condition
- 2) Write Command(Slave Address + R/W Bit(0) = 0x62) Transmission and Check Acknowledge
- 3) Write Command(ASCII 'R' : 0x52) Transmission and Check Acknowledge
- 4) I2C Stop Command
- 5) I2C Start Command
- 6) Read Command(Slave Address + R/W Bit(1) = 0x63) Transmission and Check Acknowledge
- 7) Read 7 Byte Receiving Data from Module and Send Acknowledge
(Delay at least 1ms for reading each byte)

Configuration	CO ₂	reserved	reserved	reserved	reserved								
1 Byte	2 Byte	0x00	0x00	0x00	0x00								
<table border="1" style="width: 100%; text-align: center;"> <tr> <td>0</td><td>0</td><td>0</td><td>0</td><td>1</td><td>0</td><td>0</td><td>0</td> </tr> </table>						0	0	0	0	1	0	0	0
0	0	0	0	1	0	0	0						

In need of detail protocol specification and time sequence, I2C programming guide is providable by contacting Sales Rep.

Analog Voltage Output Descriptions : Option

* Output_{voltage} = 0.5~4.5V

Output Voltage 0.5V~4.5V matches proportionally to 0 ppm up to 2,000/3,000/5,000/10,000 ppm

* CO₂ Measurement_(ppm) = ((Output_{voltage} - 0.5) / (4.5 - 0.5)Voltage) x F.S. ppm ,
cf.F.S. (ppm) : 2,000/3,000/5,000/10,000 ppm (20,000/30,000/50,000/100,000 is optional.)

EX) if the Output_{voltage} is 2.5V in 2,000 ppm (F.S. of Reading range)

$$\begin{aligned}
 \text{CO}_2 \text{ Measurement}_{\text{ppm}} &= (2.5 - 0.5) \text{ V} \div (4.5 - 0.5) \text{ V} \times 2,000. \text{ ppm} \\
 &= 0.5 \times 2,000 \text{ ppm} = 1,000 \text{ ppm}
 \end{aligned}$$

PWM Descriptions : Option

* $Measurement_{(ppm)} = (t_H - 2msec) / 1000msec \times Range_{(ppm)}$ (t_H : High Pulse Width)

* $Range_{(ppm)}$: 2,000/3,000/5,000/10,000 ppm (20,000/30,000/50,000/100,000 is optional.)

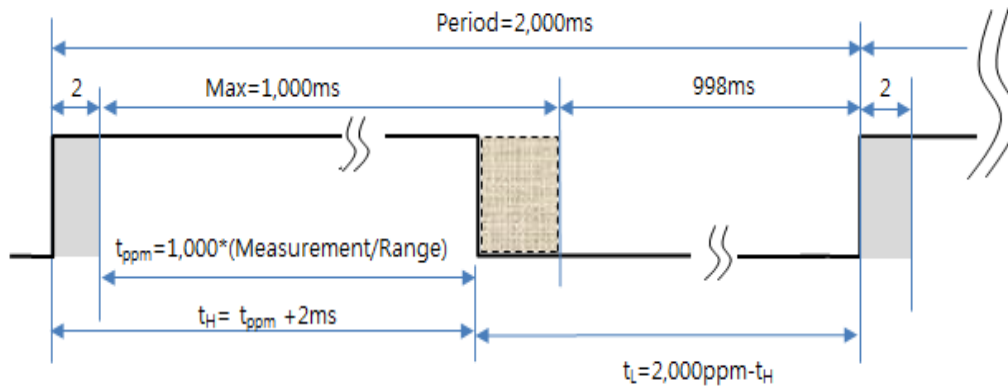

EX) t_H (High Pulse Width) calculation for 400ppm in 2,000 ppm Range.

* $Measurement_{(ppm)} = 400 ppm = (t_H - 2ms) / 2,000msec \times Range_{(ppm)}$,

* $t_H = 1,000 msec * (400 ppm / 2,000ppm) + 2msec = 202msec$

(cf: $T_L = Period - t_H = 2,000ppm - 202 msec = 1,798 msec.$)

※ Caution

1. Please hold only 'PCB' of sensor without holding Cavity directly to avoid the physical shock on sensor. Rough handling or Transportation could result in inaccurate reading.
2. Proper ESD protection during handling is important to avoid electrostatic defect occurrence. The storage of sensor should be insulated as well