

# Duct Mountable Transmitter

## DUT-1000(L)-HT / DUT-2000(L)-HT



**DUT-1000/2000**



**DUT-1000L/DUT-2000L  
(With display)**

### General

DUT-1000 and DUT-2000 are Duct-mountable CO<sub>2</sub> transmitters which detect CO<sub>2</sub> ppm concentration value inside ducts and send signal to remote host.

DUT-1000 series cover residential indoor application and DUT-2000 series include agricultural one as well. Both operate with 3 wire/4-wire & Relay and give analog output RS-485 Mod-bus protocol support model is available as well.

### Features

- Duct mountable NDIR CO<sub>2</sub> Transmitters
- Option sensor Module  
: Humidity & Temperature Sensor
- CO<sub>2</sub> ppm measurement range selectable
- With / without LCD display – Order option
- Analog current (4~20mA/0~20mA) or Voltage (0~10V/2~10V).
- RS485 Mod-bus protocol is supported.
- Relay (1A : 120V AC, or 24V DC) for CO<sub>2</sub> Fault Alarm Indicator use is available.
- Power of 24 Volt AC/DC

## DUT-1000/2000 Specifications

	DUT-1000	DUT-2000
<b>General Performance</b>		
Operation Temperature range	0°C ~ 50°C	-10°C ~ 50°C
Operating Humidity range	0 ~ 95 % RH(Non-condensing) - Indoor, Building, HVAC (ACDL)	0 ~ 99 % RH(Non-condensing), Agricultural green house, Industrious, etc
Storage Temperature	-30°C ~ 70°C	
<b>CO2 Measurement</b>		
Sensing Method	NDIR (Non-dispersive Infrared)	
CO2 Measurement range	0 ~ 2,000ppm(3K, 5K, 10K ppm are selectable) (2%, 3%, 5% optional)	0 ~ 2,000ppm(3K, 5K, 10K ppm are selectable) (2%, 3%, 5% optional)
Accuracy	±50ppm ±3% of Reading (ACDL operation)	±30ppm ±3% of Reading (ACDL or MCDL operation)
Response Time (90%)	120sec	120sec
Sampling Interval	3sec	3sec
Temperature Accuracy	±0.3°C	
Humidity Tolerance	±3%RH	
<b>Input Power</b>	24V AC/DC, ±20%, 50/60Hz, 3/4Wire(Order Option) ※ no polarity connection	
<b>Output</b>	Support of RS485 Mod-bus protocol Voltage output: 2 ~ 10V DC / Current output: 4 ~ 20mA Relay control: 1A, 120V AC, or 24V DC ※ Relay Contact (CO2 fault Alarm indicator) - Open : Normal , Close : Abnormal	
<b>Dimensions</b>	Mainboard Box : 85mm x 115mm x 45mm Duct Probe : 246mm x 40Ø	
<b>Other options</b>	LCD display	

\* Option sensor module for Humidity & Temperature,

\* Duct Probe diameter for DUT-1000 / DUT-2000 : 40 Ø

### RS485 Mod-Bus Slave Address setting

- Mod-Bus slave address can be set by DIP Switch



- DIP Switch

ON	<input type="checkbox"/>	<input type="checkbox"/>	<input type="checkbox"/>	<input type="checkbox"/>	<input type="checkbox"/>	<input type="checkbox"/>	<input type="checkbox"/>	<input type="checkbox"/>
OFF	<input type="checkbox"/>	<input type="checkbox"/>	<input type="checkbox"/>	<input type="checkbox"/>	<input type="checkbox"/>	<input type="checkbox"/>	<input type="checkbox"/>	<input type="checkbox"/>
	1	2	3	4	5	6	7	8

Example) Setting Slave Address "1"

### RS485 Mod-Bus Protocol

- Modicon Mod-Bus RTU Mode: Follow Modicon Mod-Bus protocol (<http://www.modbus.org>)
- Communication Specifications

RS-485 (2-wire, half-duplex)

Parameter	Description
Baud rate	9600 BPS
Data Bit	8 Bits
Parity Bit	None
Stop Bit	1
Flow Control	None

- Hold Register Specification (Function code 03)

- Mapping Base Address: 0x0050
- Hold Register. Max. Read Size : 4

Register Address	Value	Data Type	Unit	Description
0x0050	CO2	2 Byte WORD	PPM	Ex) 800 -> 800 PPM
0x0051	Temperature	2 Byte Integer	°C	25 °C
0x0052	Humidity	2 Byte WORD	RH	35 -> 35 RH
0x0053	Alarm	2 Byte WORD		0x1008 Hi BYTE: 0x10 x 100 :1600 (Alarm High) Lo BYTE: 0x08 x 100 : 800 (Alarm Low)

4) Preset Single Register (Function code 06)

Register Address	Value	Data Type	Unit	Description
0x1001	Alarm Low	2 Byte WORD	PPM	ex) 0x0320 (Alarm Low 800 ppm)
0x1002	Alarm High	2 Byte WORD	PPM	ex) 0x640 (Alarm High 1600 ppm)

5) Supported Function Code

- Currently supported only code 03, 06 and exception responses.
- Error code 0x83 or other (CODE + 0x80)

Exception code	Description
01	Exception of Function code
02	Exception of Starting Address
03	Exception of Quantity of Registers

6) Example How to get value from DUT-1000(2000) by Mod-Bus protocol

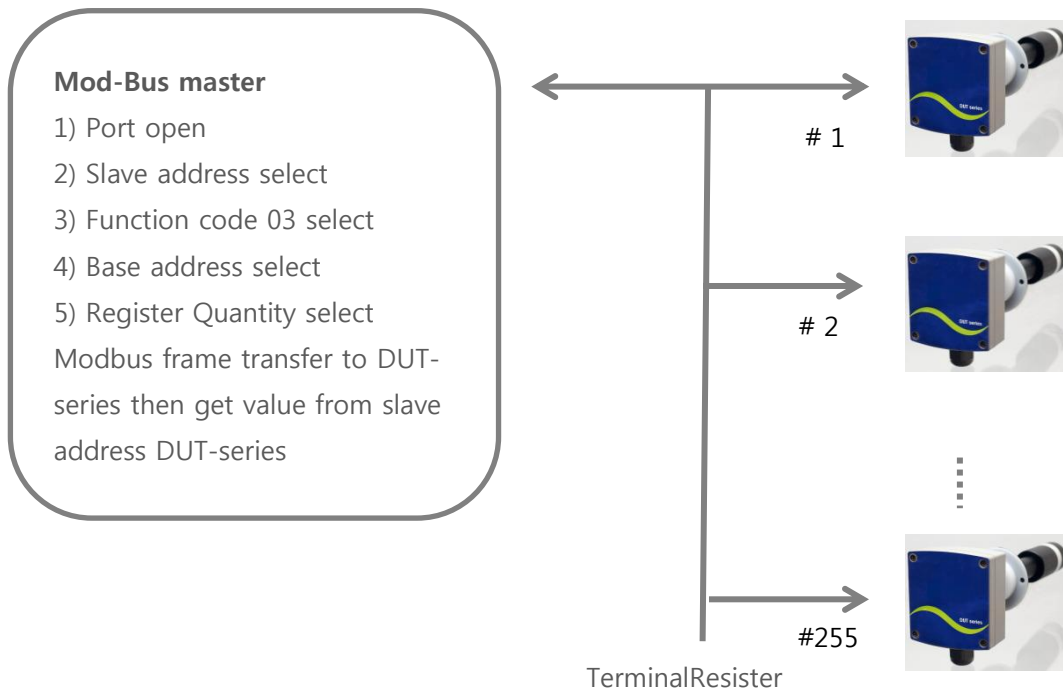

## LCD Display (option)

- CO2

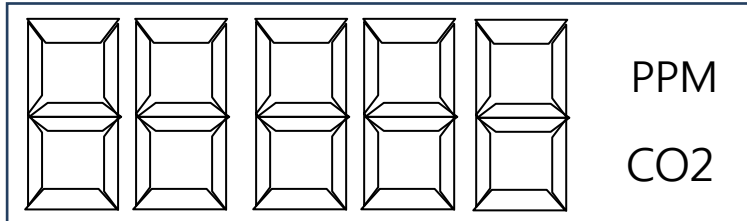

- Temperature & Humidity (option)

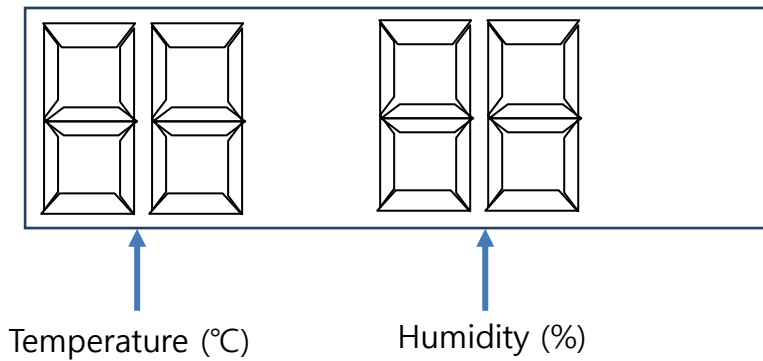

### Display order

- 1) CO2 display during 6 seconds
  - 2) Temp & Humidity 3 seconds
  - 3) Repeated
- ※ If not installed temp & humidity module then skip about temp & humidity

### Error code display

- 1) E1 : CO2 sensor fault message

◆ APPENDIX

● Terminal(J) Description

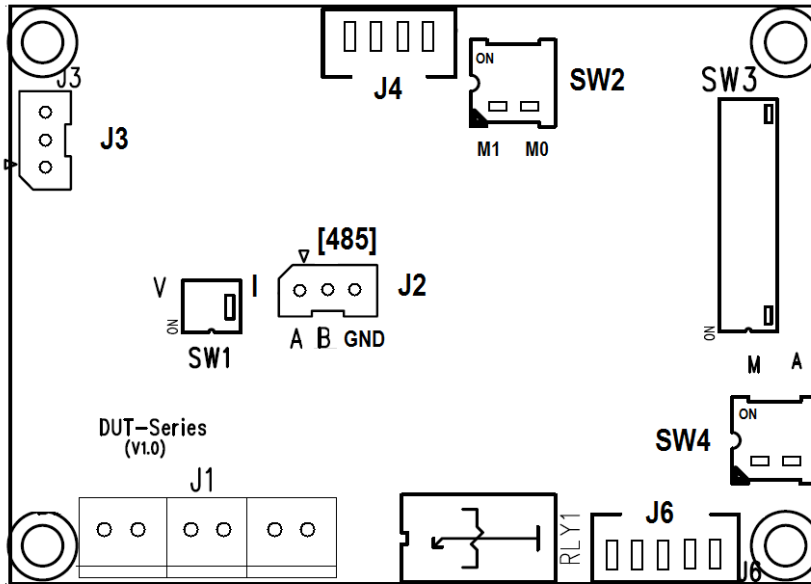

- J1 : Main terminal
  - ※ 3-Wire connection (24VDC only) : +24V ← GND(common) → AOUT
  - ※ Input Power (24V AC/DC) : No polarity

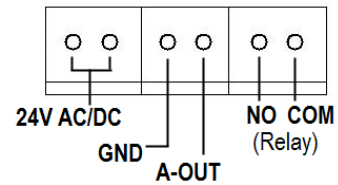

- J2 : RS 485 terminal

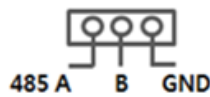

- J3 : LCD terminal



- J4 : Temp & Humidity terminal
  - 4pin supplied with HT-200 (temp & humidity module)

- J6 : CO2 sensor module terminal (5pin supplied with CO2 module)

● Switch(SW) Description

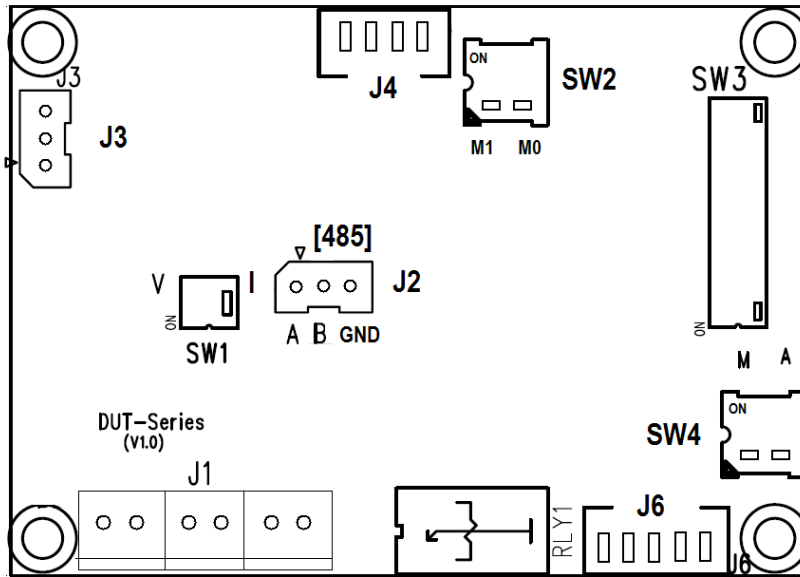

- SW1 : A-OUT selectable



ON: 2-10V Voltage out



OFF: 4-20ma Current out

- SW2 : Co2 Range selectable



10000 ppm range



5000 ppm range



3000 ppm range



2000 ppm range

- SW3 : MODBUS Slave Address can be set by DIP Switch



• DIP Switch (SW3)

ON	<input type="checkbox"/>	<input type="checkbox"/>	<input type="checkbox"/>	<input type="checkbox"/>	<input type="checkbox"/>	<input type="checkbox"/>	<input type="checkbox"/>	<input type="checkbox"/>
OFF	<input type="checkbox"/>	<input type="checkbox"/>	<input type="checkbox"/>	<input type="checkbox"/>	<input type="checkbox"/>	<input type="checkbox"/>	<input type="checkbox"/>	<input type="checkbox"/>
	1	2	3	4	5	6	7	8

Example) Setting Slave Address "3"

- SW4 : Calibration Switch (MCDL, ACDL) of CO2 sensor module

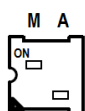

MCDL operation



ACDL operation



Default

### [Appendix – A] Assembly Drawings (DUT-1000/2000)

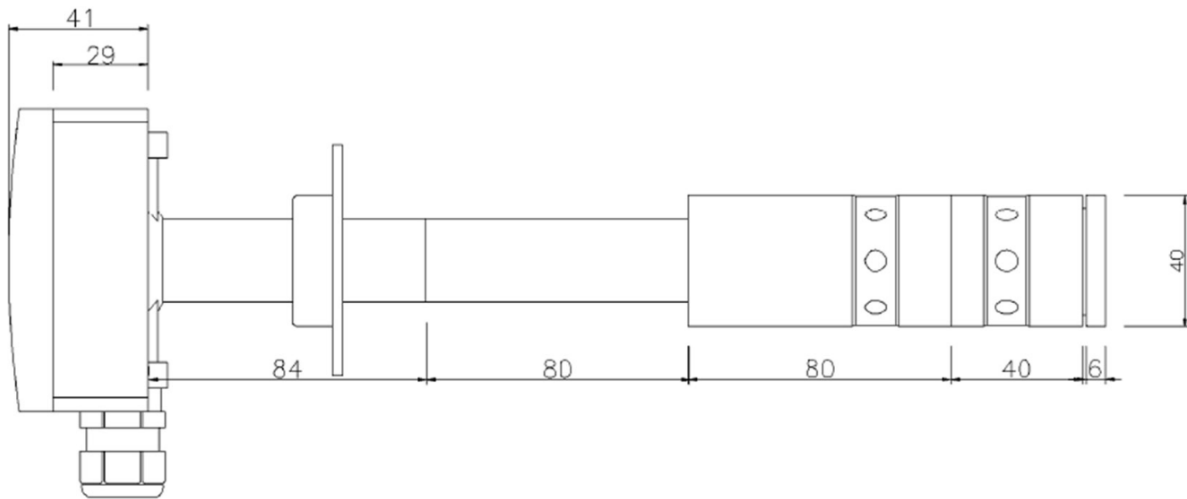
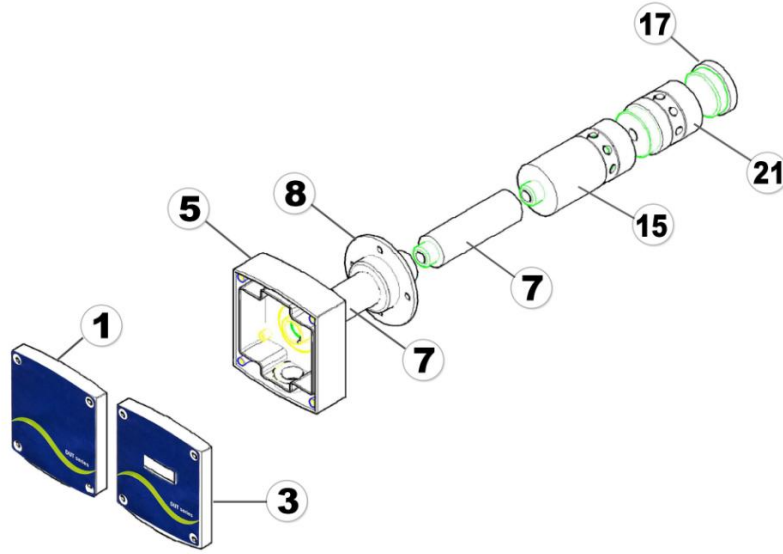

The length of CO2 probe is 250mm (84+80+80+6) as default and extendable to 290mm with 40mm for Temp/Humidity probe<sup>21</sup>.

Or could be shorten to 116mm (by deduction of 80mm-pipe<sup>7</sup> and replace Sensor Probe<sup>15</sup> to 110mm) .

< Table. 1 > Part lists

NO	Description	Code	Remarks
1	Main Board Box Cover (A)	M0-A	
2	Cover Label A (basic)	M0-A-L1	
3	Main Board Box Cover (B)	M0-B	
4	Cover Label B (with LCD)	M0-B-L2	



<b>5</b>	<b>Main Board Box (Connection Box)</b>	M1	
6	Main Board Box Gasket	M1-G1	
<b>7</b>	<b>Extension Probe</b>	M1-P1	L= 80mm, 25Ø
<b>8</b>	<b>Mounting Frange</b>	M1-MF	
9	Mounting Frange Gasket	M1-MF-G2	
<b>15</b>	<b>CO2 Sensor Probe</b>	M1-SPB	L= 86mm, 40Ø
16	Dust Filter	M1-SPB-F2	
<b>17</b>	<b>Probe End-Cap</b>	M1-SPB-E2	L= 6mm, 40Ø
18	Spondge Gasket	M1-SPB-G4	
19	Sealing Gasket (Probe inside)	M1-SPA-G4	
<b>21</b>	<b>HT-200</b>	M1-HTPB	L= 40mm, 40Ø (Humidity & Temperature sensor)

## [Appendix – B] Dimensional Drawings

### 1. Front Cover

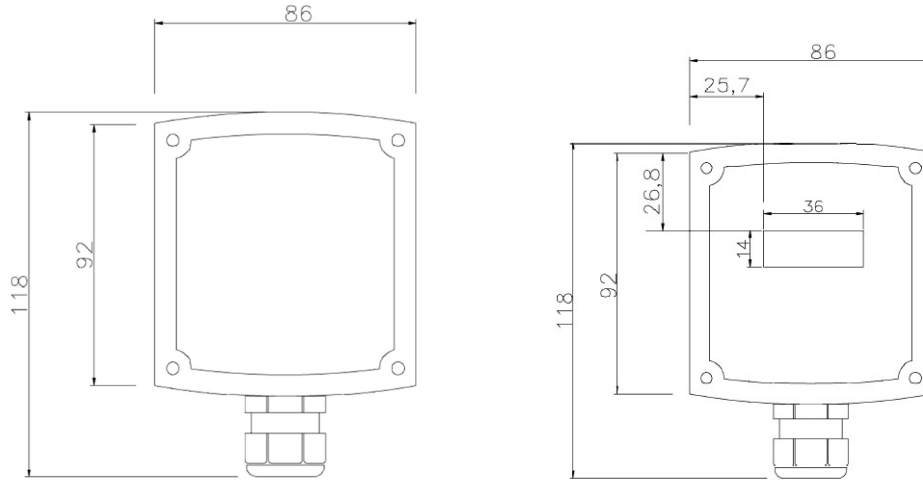

### 2. Maximum size : CO2 + Temperature = 290mm (84 + 80 + 80 + 40 +6)

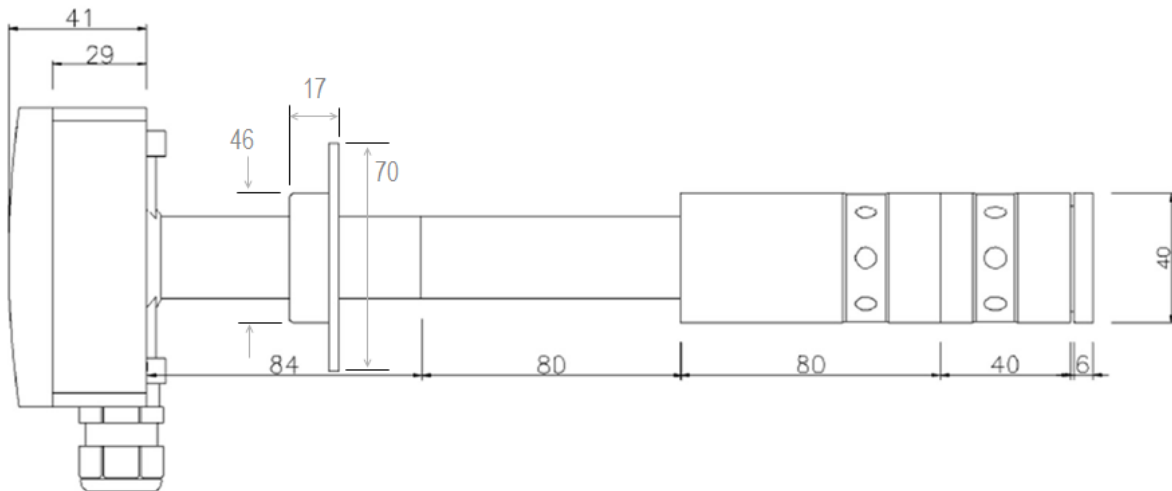

### 3. Minimum size : CO2 = 116mm

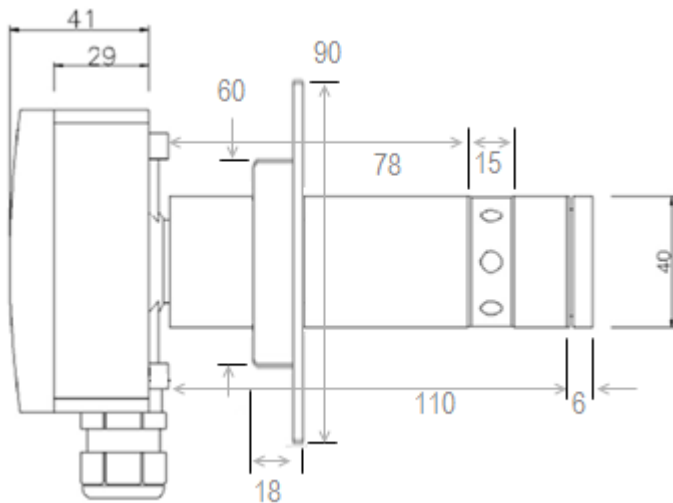

**ELT Sensor Corp.**

(ChunuiTechnopark 101-909) 36, Bucheon-ro198beon-gil,  
reserved.Wonmi-gu, Bucheon-si, Gyeonggi-do, 420-857, Korea  
Printed  
Phone :82-32-719-8055

Fax : 82-70-8677-8055  
<http://www.eltsensor.o.kr>

2015 ELT Sensor All rights  
Subject to change without notice.

2015. Nov

