

# Product Data Sheet

## Product Datasheet A7EF Carbon Monoxide Sensor

### Document Purpose

The purpose of this document is to present the performance specification of the A7EF Carbon Monoxide gas sensor.

This document should be used in conjunction with the Operating Principles (OP20) and the Product Safety Datasheet (PSDS 15).

The data provided in this document are valid at 20°C, 50% RH and 1013 mBar for 3 months from the date of sensor manufacture.

Output signal can drift below the lower limit over time. For guidance on the safe use of the sensor, please refer to the Operating Principles OP20.

## Product Data Sheet

### Key Features & Benefits:

- Robust, industry standard 7-Series packaging
- Compact Size

### Technical Specifications

#### MEASUREMENT

<b>Operating Principle</b>	4-electrode electrochemical
<b>Measurement Range</b>	0-1000 ppm CO
<b>Maximum Overload</b>	2000 ppm CO
<b>Filter</b>	To remove H <sub>2</sub> S
<b>Auxillary Electrode</b>	To compensate for hydrogen cross interference
<b>Sensitivity*</b>	0.10 ± 0.02 µA/ppm
<b>Response Time (T<sub>90</sub>)*</b>	<35 Seconds at 20°C
<b>Baseline Offset (clean air)*</b>	-2 to +15 ppm CO equivalent
<b>Resolution</b>	0.5 ppm (when used with recommended electronics)
<b>Repeatability</b>	1% of signal
<b>Linearity</b>	Linear

#### ELECTRICAL

<b>Recommended Load Resistor</b>	10 Ω
<b>Bias Voltage</b>	0 or +250 mV

#### MECHANICAL

<b>Weight</b>	25 g
<b>Housing Material:</b>	
Cap	Polycarbonate
Body	ABS
<b>Orientation</b>	Any

#### ENVIRONMENTAL

<b>Operating Temperature Range</b>	-20°C to +50°C
<b>Recommended Storage Temp</b>	0°C to 20°C
<b>Operating Pressure Range</b>	Atmospheric ± 10%
<b>Pressure Coefficient</b>	0.02% signal / mBar
<b>Operating Humidity Range</b>	15 - 90% RH non-condensing

#### LIFETIME

<b>Long Term Sensitivity Drift*</b>	<5% signal loss/year
<b>Expected Operating Life</b>	3 years in air
<b>Storage Life</b>	6 months in CTL container

**NOTE:** For emissions monitoring applications, use the A3EF CiTiceL

### Product Dimensions

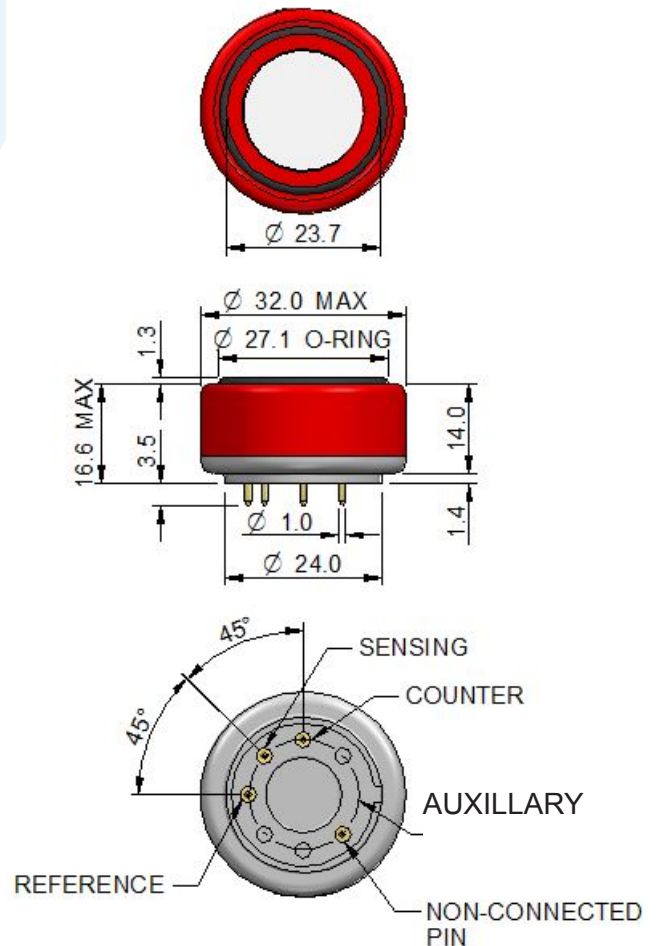

All dimensions in mm

All tolerances ±0.15 mm unless otherwise stated

**IMPORTANT NOTE:** Connection should be made via PCB sockets only. Soldering to the pins will seriously damage your sensor and invalidate the warranty.

\* Specifications are valid at 20°C, 50% RH and 1013 mBar, using City Technology recommended circuitry. Performance characteristics outline the performance of sensors supplied within the first 3 months. Output signal can drift below the lower limit over time.

# Product Data Sheet

## Poisoning

CiTiceLs are designed for operation in a wide range of environments and harsh conditions. However, it is important that exposure to high concentrations of solvent vapours is avoided, both during storage, fitting into instruments and operation.

When using sensors with printed circuit boards (PCBs), degreasing agents should be used before the sensor is fitted. Do not glue directly on or near the CiTiceL as the solvent may cause crazing of the plastic.

## Cross Sensitivity Table

Whilst CiTiceLs are designed to be highly specific to the gas they are intended to measure, they will still respond to some degree to various other gases. The table below is not exclusive and other gases not included in the table may still cause a sensor to react.

**IMPORTANT NOTE : The cross sensitivity data shown below does not form part of the product specification and is supplied for guidance only. Values quoted are based on tests conducted on a small number of sensors and any batch may show significant variation. For the most accurate measurements, an instrument should be calibrated using the gas under investigation.**

Gas	Concentration Used (ppm)	A7EF (ppm CO)
Hydrogen Sulfide, H <sub>2</sub> S	15	≈ 1
Sulfur Dioxide, SO <sub>2</sub>	5	0
Nitric Oxide, NO	35	< 7
Nitrogen Dioxide, NO <sub>2</sub>	50	-0.5 < x\$ < 1.0
Chlorine, Cl <sub>2</sub>	1	0
Hydrogen, H <sub>2</sub>	100	0
Hydrogen Cyanide, HCN	10	< 2
Hydrogen Chloride, HCl	5	0
Ethylene, C <sub>2</sub> H <sub>4</sub>	100	< 75

### **SAFETY NOTE**

This sensor is designed to be used in safety critical applications. To ensure that the sensor and/or instrument in which it is used, are operating properly, it is a requirement that the function of the device is confirmed by exposure to target gas (bump check) before each use of the sensor and/or instrument. Failure to carry out such tests may jeopardize the safety of people and property.

Every effort has been made to ensure the accuracy of this document at the time of printing. In accordance with the company's policy of continued product improvement City Technology Limited reserves the right to make product changes without notice. The products are always subject to a programme of improvement and testing which may result in some changes in the characteristics quoted. As the products may be used by the client in circumstances beyond the knowledge and control of City Technology Limited, we cannot give any warranty as to the relevance of these particulars to an application. It is the clients' responsibility to carry out the necessary tests to determine the usefulness of the products and to ensure their safety of operation in a particular application.