

- Key Features & Benefits:**
- Robust, 3-Series packaging
 - Range of accessories available

Technical Specifications

MEASUREMENT

Operating Principle	3-electrode electrochemical
Measurement Range	0-1000 ppm CO
Maximum Overload	2000 ppm CO
Filter	None
Sensitivity	0.10 ± 0.02 µA/ppm
Resolution	0.5 ppm CO
Response Time (T₉₀)	<25 seconds
Baseline Offset (clean air)	-1 to +3 ppm equivalent
Zero Shift (+20°C to +40°C)	<9 ppm equivalent
Repeatability	1% of signal
Linearity	Linear

ELECTRICAL

Recommended Load Resistor	10 Ω
Bias Voltage	Not Required

MECHANICAL

Weight	22 g
Housing Material	20% Glass Filled Polypropylene
Orientation	Any

ENVIRONMENTAL

Typical Applications	Fixed Life Safety
Operating Temperature Range	-20°C to +50°C
Recommended Storage Temp	0°C to 20°C
Operating Pressure Range	Atmospheric ± 10%
Pressure Coefficient	0.020 ± 0.008 % signal/mBar
Operating Humidity Range	15 - 90% RH non-condensing

LIFETIME

Long Term Sensitivity Drift	<5% signal loss/year
Expected Operating Life	Three years in air
Storage Life	6 months in CTL container
Standard Warranty	12 months from date of despatch

Product Dimensions

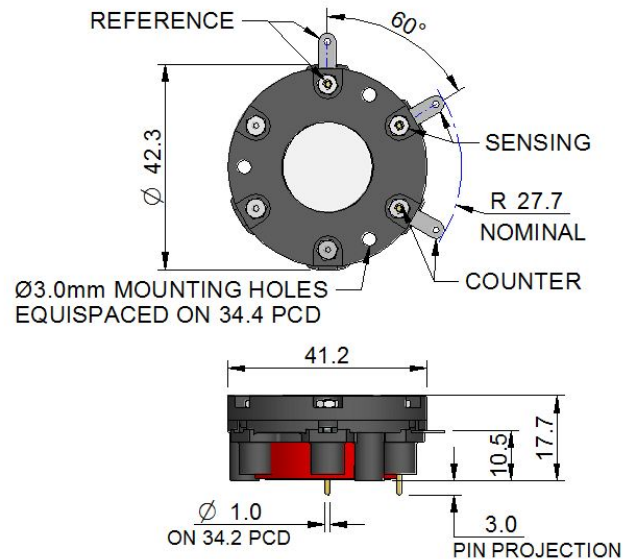

All dimensions in mm
All tolerances ±0.15 mm
unless otherwise stated

AVAILABLE OPTIONS

Sensor	Description	Part Number
3E	With side tag and PCB pin connections	AB004-J40
3E(S)	With side tag connection	AB004-040
3E(G)	With gold-plated PCB pin connection	AB004-340

IMPORTANT NOTE:

Soldering to the pin connections will seriously damage the sensor and invalidate the warranty.

All performance data is based on conditions at 20°C, 50% RH and 1013 mBar, using City Technology recommended circuitry. For sensor performance data under other conditions, refer to Operating Principles OP08 or contact City Technology.

Poisoning

CiTiceLs are designed for operation in a wide range of environments and harsh conditions. However, it is important that exposure to high concentrations of solvent vapours is avoided, both during storage, fitting into instruments and operation.

When using sensors with printed circuit boards (PCBs), degreasing agents should be used before the sensor is fitted. Do not glue directly on or near the CiTiceL as the solvent may cause crazing of the plastic.

Cross Sensitivity Table

Whilst CiTiceLs are designed to be highly specific to the gas they are intended to measure, they will still respond to some degree to various gases. The table below is not exclusive and other gases not included in the table may still cause a sensor to react.

Gas	Concentration Used	3E (ppm CO)
Hydrogen Sulfide, H ₂ S	15	≈ 50
Sulfur Dioxide, SO ₂	5	≈ 3
Nitric Oxide, NO	35	≈ 10
Nitrogen Dioxide, NO ₂	5	≈ -3
Chlorine, Cl ₂	1	0
Hydrogen, H ₂	100	<60
Hydrogen Cyanide, HCN	10	≈ 5
Hydrogen Chloride, HCl	5	0
Ethylene, C ₂ H ₄	100	≈ 90

The cross-sensitivity values quoted are based on tests conducted on a small number of sensors. They are intended to indicate sensor response to gases other than the target gas. Sensors may behave differently with changes in ambient conditions and any batch may show significant variation from the values quoted.

SAFETY NOTE

This sensor is designed to be used in safety critical applications. To ensure that the sensor and/or instrument in which it is used, are operating properly, it is a requirement that the function of the device is confirmed by exposure to target gas (bump check) before each use of the sensor and/or instrument. Failure to carry out such tests may jeopardize the safety of people and property.

Every effort has been made to ensure the accuracy of this document at the time of printing. In accordance with the company's policy of continued product improvement City Technology Limited reserves the right to make product changes without notice. No liability is accepted for any consequential losses, injury or damage resulting from the use of this document or from any omissions or errors herein. The data is given for guidance only. It does not constitute a specification or an offer for sale. The products are always subject to a programme of improvement and testing which may result in some changes in the characteristics quoted. As the products may be used by the client in circumstances beyond the knowledge and control of City Technology Limited, we cannot give any warranty as to the relevance of these particulars to an application. It is the clients' responsibility to carry out the necessary tests to determine the usefulness of the products and to ensure their safety of operation in a particular application. Performance characteristics on this data sheet outline the performance of newly supplied sensors. Output signal can drift below the lower limit over time